

Genuine Metaris MH Series Dump Pumps

Rugged, Reliable and Totally Interchangeable

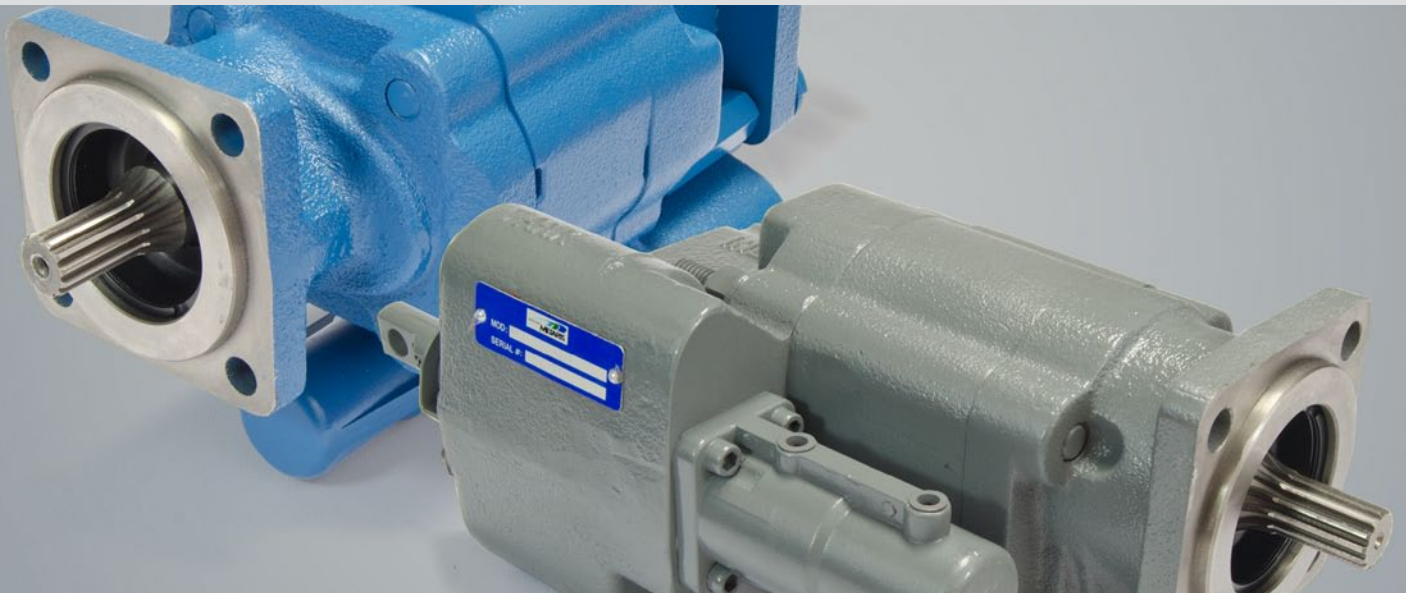

Offering Remote Mount, Direct Mount and Dual Pressure Options

Genuine Metaris Dump Pumps are known for their ruggedness, reliability and interchangeability. Available in both the 101 Remote Mount and the 102 Direct Mount configurations and C or G frames, these pumps offer cast iron construction, a variety of displacements and “Air Shift” capabilities.

Our Dual Pressure Dump Pumps come equipped with two relief pressures on them: high pressure (3000 psi) for Walking Floor® applications and low pressure (2000 psi) for dump applications, each is selectable by a supplied air switch.

- Remote Mount, Direct Mount and Dual Pressure Options
- 3 Piece Cast Iron Construction
- High Pressure Shaft Seals
- Direct Acting Relief C/W Load Check
- Pressure Balance Thrust Plates
- Heavy Duty Roller Bearing
- Two or Three Line Hook-up
- Optional Airshift Control
- Factory set Relief Pressure at 2000 psi
- Optional Mounting Bracket
- Dowelled for Higher Pressure

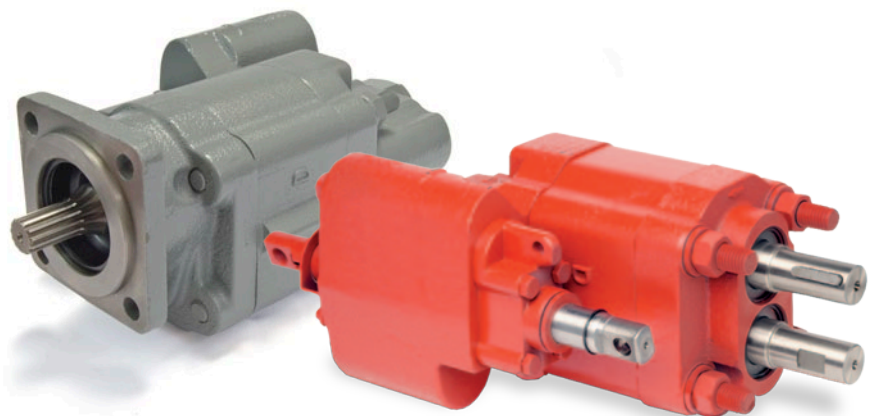

Options and Flexibility

Model Code Breakdown

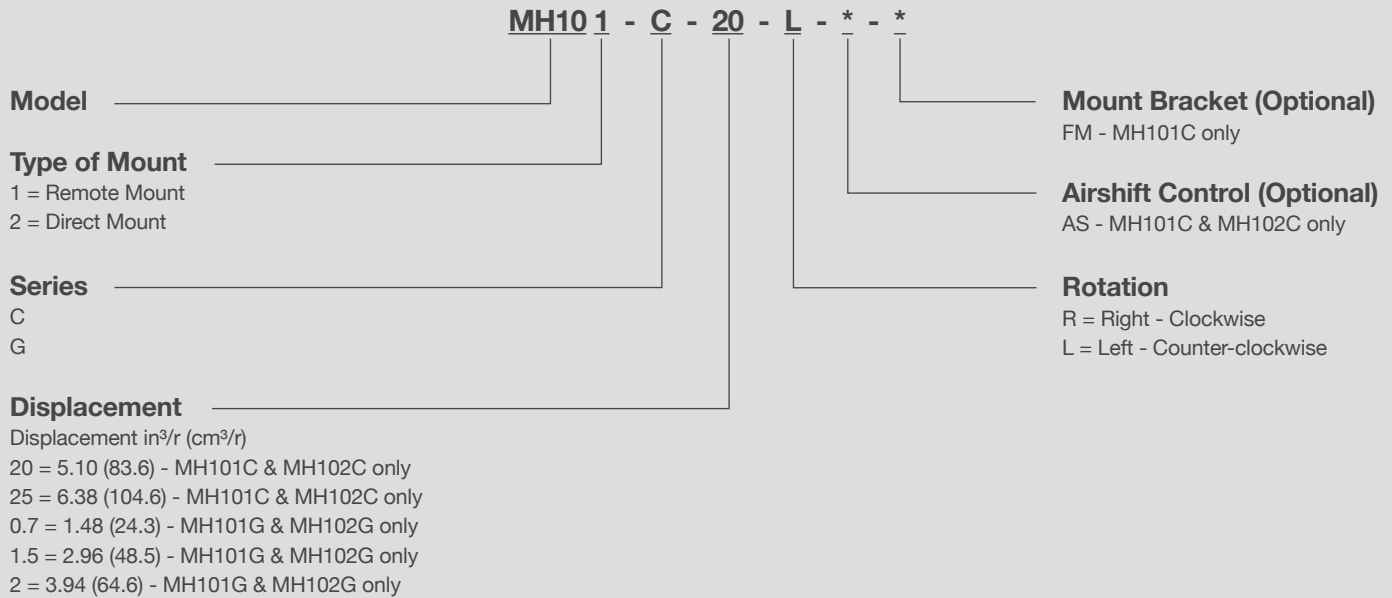

Pump Series	Remote Mount	Direct Mount	Flow at 1800 RPM (gpm / lpm)				Max RPM	Max Pressure (psi / BAR)
			3/4"	1-1/2"	2"	2-1/2"		
MH101G	X		9.5 / 36	21 / 79.5	29 / 109.3	-	1800	2500 / 173
MH101C	X		-	-	39 / 147	48 / 180.5	1800	2500 / 173
MH102G		X	9.5 / 36	21 / 79.5	29 / 109.3	-	1800	2500 / 173
MH102C		X	-	-	39 / 147	48 / 180.5	1800	2500 / 173



Air Shift Kits

The Genuine Metaris airshift cylinder converts a manual pump into an airshift dump pump. This unit can be factory installed or sold separately.



L Mounting Bracket

Our optional Genuine Metaris mounting bracket for the MH101C model dump pump.

MH101 Series Dump Pumps

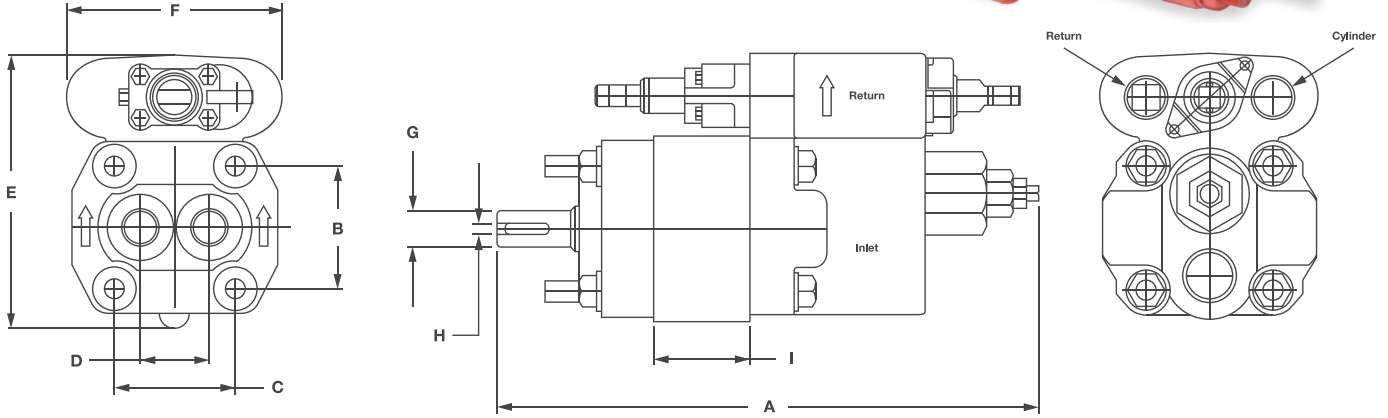
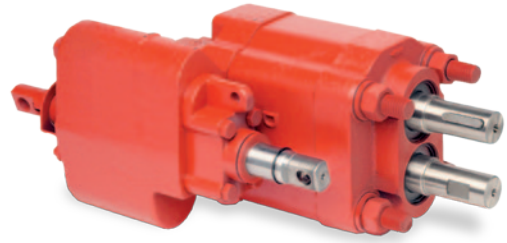

Pump Series	A	B	C	D	E	F	G	H	I (25)	I (20)	I (1.5)	I (.75)	J
MH101C	13.12+GW	3.56	3.56	2	7.94	6.25	.998	.25	3.25	2.75	-	-	-
MH101G	10.56	-	-	1.75	6.12	5.25	.998	.25	-	2	.75	1	-

* Measurements are in inches.

MH102 Series Dump Pumps

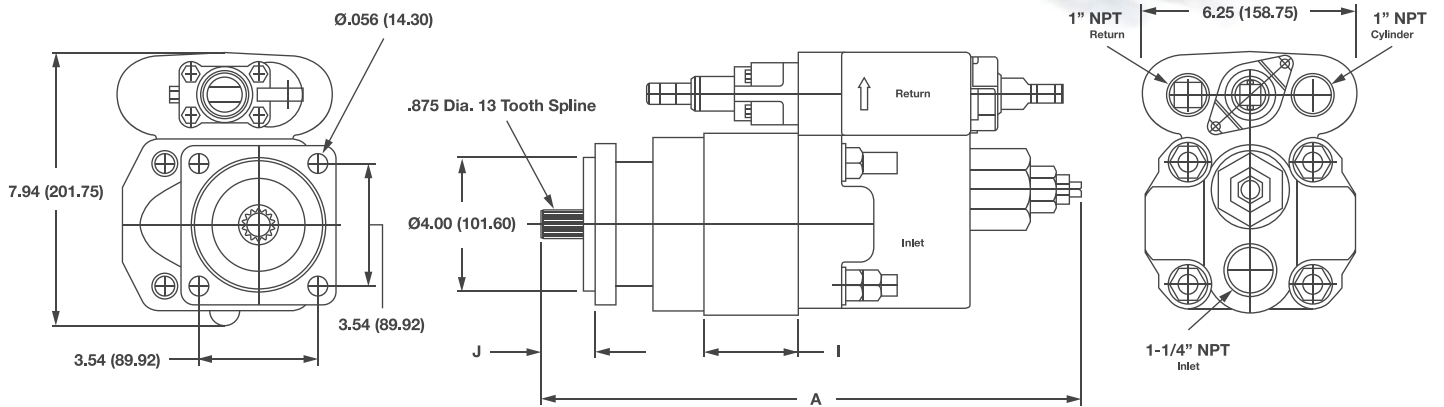

Pump Series	A	B	C	D	E	F	G	H	I (25)	I (20)	I (1.5)	I (.75)	J
MH102C	13.62+GW	-	-	-	7.94	6.25	.875	-	3.25	2.75	-	-	1.62
MH102G	11.38+GW	-	-	-	7.94	6.25	.875	-	-	2	.75	1	1.31

* Measurements are in inches.

MHWFD Series Dump Pumps

- Dual Pressure Pump with Direction Control Valve
- Pump Utilizes Two Relief Pressure:
 - High Pressure (3000 psi) for Walking Floor® Applications
 - Low Pressure (2000 psi) for Dump Applications
- Factory Set Relief Pressures - these should not be adjusted
- Includes Air Switch - used to switch between high and low pressure
- Pump Mounting Bracket Included
- Set up as a 3-Line System only

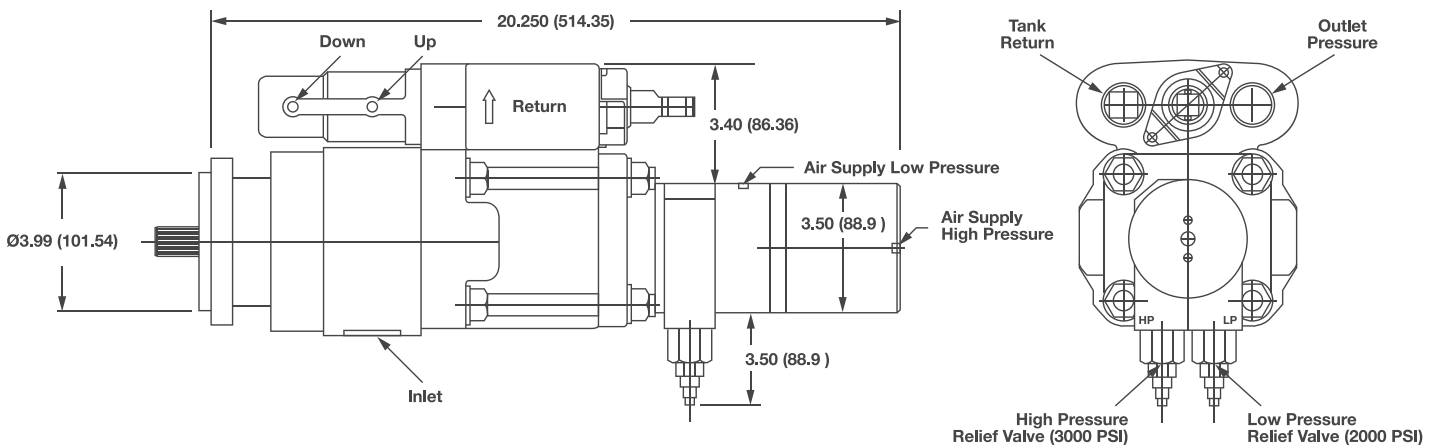

Counter Clock-wise Rotation View

Pump Series	Displacement (in ³ /r)	Displacement (cm ³ /r)	Flow at 1200 RPM (gpm / lpm)	Max RPM	Pressure (psi)
MHWFD2.0	5.1	83.6	26.5 / 100.3	1800	2000-3000

* Air pressure must be 80 psi minimum to operate the high/low pressure relief air cylinder.
 ** PTO is required to operate at 130% of the engine speed. In most applications, the engine RPM is 1000-1200rpm when equipped with a Genuine Metaris PTO - this will be a 'C' or 'E' ratio.

Walking Floor® is a registered trademark not owned by or affiliated with Metaris or Hydraulex Global.



Hydraulex Corporate
 48175 Gratiot Ave
 Chesterfield, MI 48051
 Toll Free: 800.422.4279
 Tel: 586.949.4240

www.hydraulex.com

Hydraulex Detroit
 Hydraulex Jackson
 Hydraulex Seattle
 Hydraulex Memphis

Tel: 586.949.4240
 Tel: 601.469.1987
 Tel: 253.604.0400
 Tel: 901.794.2462

sales@hydraulex.com
sales@metarisusa.com
hrrdsales@hydraulex.com
fhisales@hydraulex.com



Connect with us:

All manufacturers names, symbols and descriptions in this document are used for reference purposes only, and it is not implied that any parts listed is the product of these manufacturers.