

# Genuine Metaris Vane Product Technical Catalog

Pumps & Components - V10/V20, VTM, V, VQ, VQH Series



# Contents

	Series	Page
General	<b>V10/V20 Series</b>	<b>4</b>
	Features	4
	Model Code Breakdown	5
	Parts Breakdown	6
	V10 Dimensions	7
	V20 Dimensions	8
	V10/V20 Optional Shaft Dimensions	9
	V10F Flow Control Valve Dimensions	10
	V20F Flow Control Valve Dimensions	11
	V10/V20 Priority Covers	12
	V10/V20 Optional Port Positions	13
	V10NF Model Code Breakdown	14
	V10NF Parts Breakdown	15
	V20NF Model Code Breakdown	16
	V20NF Parts Breakdown	17
	<b>V2010/V2020 Series</b>	<b>18</b>
	Features	18
	V2010 Model Code Breakdown	19
	V2010 Parts Breakdown	20
	V2010 Dimensions	21
	V2020 Model Code Breakdown	22
	V2020 Parts Breakdown	23
	V2020 Dimensions	24
	<b>VTM42 Series</b>	<b>25</b>
	Features	25
	Model Code Breakdown	26
	Parts Breakdown	27
	Dimensions	28
	<b>V Series - Single Pump</b>	<b>29</b>
	Features	29
	<b>VQ Series - Single Pump</b>	<b>30</b>
Features	30	
V/VQ Model Code Breakdown	31	

# Contents

Series	Page
V Series Parts Breakdown	32
VQ Series Parts Breakdown	34
V/VQ Series Dimensions	36
<b>V/VQ Series - Double Pump</b>	<b>38</b>
Features	38
Model Code Breakdown	40
V Series Parts Breakdown	41
VQ Series Parts Breakdown	45
V/VQ Dimensions	49
Shaft Dimensions	51
<b>V/VQ Series - Thru-drive Single Pump</b>	<b>52</b>
Features	52
Model Code Breakdown	53
Dimensions	54
Rear Mountings Dimensions	56
V/VQ Series Max Torque Loading	58
<b>VQH 32 Series</b>	<b>59</b>
High Pressure Pump & Cartridge Kits	59
<b>Pump &amp; Cartridge Identification</b>	<b>60</b>
Pump & Cartridge Identification & Rotation	60

Cross-referenced parts from the Original Equipment Manufacturer "OEM" are listed for information purposes only. Trademarks identifying these parts for cross-reference are those of each OEM and are the property of their owners and are not used, or authorized for use, by Hydralex or its affiliates. Hydralex is not affiliated with the Original Equipment Manufacturer "OEM" or licensed or authorized to produce unit or parts for the OEM. All units and parts offered in this catalog are manufactured by Hydralex and not by the OEM.

# V10/V20 Series

## Features

Balanced vane type pumps are excellent for medium- to low-pressure mobile and industrial applications. Available with integrated flow control valves to simplify system design and installation, these pumps are commonly used as pilot and auxiliary pumps for complex systems, and on heavy-duty trucks and interstate buses. Compact size and ease of service allow maximum equipment design flexibility.

- High Performance
- Pressure-balanced
- Low Cost/Economical
- Engineered for Extended Life
- Versatile and Low Noise



## Specifications

PUMP	FLOW IN GPM @ 1200 RPM & 100 PSI (LPM)	DISPL. IN <sup>3</sup> /R (CM <sup>3</sup> /R)	MAX. SPEED (RPM)	MAX. PRESSURE PSI (BAR)	TYP. DELIVERY GPM @ MAX. SPEED & PRESSURE (LPM)	TYPICAL INPUT POWER HP @ MAX. SPEED & PRESSURE (KW)	WEIGHT LBS (KG)
<b>V10</b>	1 (3.8)	0.20 (3.3)	4800	2500 (172)	3.60 (13.6)	7.00 (5.2)	10-15 (4.5-6.8)
	2 (7.6)	0.40 (6.6)	4500	2500 (172)	7.30 (27.6)	13.6 (10.1)	
	3 (11.4)	0.60 (9.8)	4000	2500 (172)	9.40 (35.6)	17.8 (13.3)	
	4 (15.1)	0.80 (13.1)	3400	2500 (172)	10.9 (41.3)	20.4 (15.2)	
	5 (18.9)	1.00 (16.4)	3200	2500 (172)	12.8 (48.5)	22.8 (17)	
	6 (23.1)	1.19 (19.5)	3000	2200 (152)	14.6 (55.3)	24.5 (18.3)	
	7 (27.2)	1.39 (22.8)	2800	2000 (138)	16.0 (60.6)	24.0 (17.9)	
<b>V20</b>	6 (23.5)	1.19 (19.5)	3400	2500 (172)	16.1 (60.9)	29.0 (21.6)	16-18 (7.3-8.2)
	7 (26.9)	1.39 (22.8)	3000	2500 (172)	16.7 (63.2)	29.5 (22)	
	8 (31)	1.62 (26.5)	2800	2500 (172)	17.7 (67)	32.5 (24.2)	
	9 (34.8)	1.80 (29.7)	2800	2500 (172)	19.8 (75)	35.5 (26.5)	
	11 (43.5)	2.22 (36.4)	2500	2500 (172)	22.9 (86.7)	37.5 (28)	
	12 (45.4)	2.38 (39)	2400	2200 (152)	23.0 (87.1)	36.0 (26.8)	
	13 (51.1)	2.59 (42.4)	2400	2200 (152)	25.9 (98)	39.0 (29.1)	

Values based on using anti-wear type petroleum oil 150 SUS at 100° F (ISO rating of 32 cSt at 38° C) and 0 psi inlet pressure.

# V10/V20 Series

## Model Code Breakdown

V10 - \* - 1 - P - 6 - P - 1 - C - \* - \* - 20 - \*\*\* - L

### Vane Pump Series

V10 = Series

V20 = Series

### Integral Valve Option

\* = Omit if not required

F = Flow Control & Relief

P = Priority Valve & Relief

### Mounting

1 = 2 Bolt Flange SAE "A" size

4 = 6 Bolt Flange Round (V20 Size only)

6 = 2 Bolt Flange SAE "B" size (V20 Size only)

### Inlet Port Connections

H = 10 Size 1" OD Tube Connection

B = 10 size G 1"

K = 10 Size 1.312" - 12 UN 2B Thd. Connection

P = 10 Size 1" NPT Pipe Thd. Connection

S = 10 Size 1.312" - 12 Straight Thd. Connection

T = 10 Size 1.1875" - 12 Straight Thd. Connection

B = 20 size G 1-1/4"

E = 20 Size 1.5" 2 Bolt Flange Connection

F = 20 Size 1.156" 2 Bolt Flange Connection

P = 20 Size 1.250" NPT Pipe Thd. Connection

R = 20 Size 1" NPT Pipe Thd. Connection

S = 20 Size 1.625" - 12 UN 2B Thd. Connection

### SAE Rated Capacity in U.S. gpm

All values rated at 1200 rpm & 100 psi gpm (lpm)

#### V10 Size

1 = 1 gpm (3.8) 5 = 5 gpm (18.9) 6 = 6 gpm (23.5) 10 = 10 gpm (37.8)

2 = 2 gpm (7.6) 6 = 6 gpm (23.1) 7 = 7 gpm (26.9) 11 = 11 gpm (43.5)

3 = 3 gpm (11.4) 7 = 7 gpm (27.2) 8 = 8 gpm (31) 12 = 12 gpm (45.4)

4 = 4 gpm (15.1) 9 = 9 gpm (34.8) 13 = 13 gpm (51.1)

#### V20 Size

### Shaft Rotation

\* = Omit for Right-hand (Clockwise) Rotation

L = Left-hand (Counter-Clockwise) Rotation

### Special Features Suffix

### Design

20 = Subject to change

(Installation dimensions will remain the same)

### Pressure Setting

A = 250 psi (17.2 bar) F = 1500 psi (103.4 bar)

B = 500 psi (34.5 bar) G = 1750 psi (120.7 bar)

C = 750 psi (51.7 bar) H = 2000 psi (137.9 bar)

D = 1000 psi (68.9 bar) J = 2250 psi (155.1 bar)

E = 1250 psi (86.2 bar) K = 2500 psi (172.4 bar)

### Flow Rate Through Orifice in Cover

1 = 1 gpm (3.8 lpm) - V10

2 = 2 gpm (7.6 lpm) - V20

8 = 8 gpm (31 lpm) - V20

### Position of Primary Outlet Port

A = Opposite Inlet Port (Viewed from Cover End of Pump)

B = 90° CCW from Inlet (Viewed from Cover End of Pump)

C = Inline with Inlet Port (Viewed from Cover End of Pump)

D = 90° CW from Inlet (Viewed from Cover End of Pump)

### Shafts

1 = Straight Keyed

3 = Threaded w/ Woodruff Key

4 = Threaded

11 = 9 Tooth Splined (V10 only)

12 = 13 Tooth Splined (V10 only)

15 = 13 Tooth Splined

27 = Tang Drive

34 = Threaded

38 = 11 Tooth Splined

62 = SAE "A" Spline (V20 only)

### Outlet Port Connections

Mode	Priority Cover	Priority Cover			Flow Control Cover		Standard Cover
		Primary	Secondary	Tank	Pressure	Tank	Pressure
K	V10	9/16-18 Str. Thd.	3/4-16 Str. Thd.	9/16-18 Str. Thd.	-	-	-
B	V10	-	-	-	-	-	G 1/2"
B	V20	-	-	-	-	-	G 3/4"
P	V10	-	-	-	3/4-16 Str. Thd.	1/2-NPT Thd.	1/2-NPT Thd.
P	V20	-	-	-	3/4-16 Str. Thd.	1/2-NPT Thd.	3/4-NPT Thd.
R	V10	-	-	-	-	-	1.062-12 Str. Thd.
S	V20	-	-	-	3/4-16 Str. Thd.	1 1/16-12 Str. Thd.	1.062-12 Str. Thd.
S	V10	-	-	-	-	-	3/4-16 Str. Thd.
T	V10	-	-	-	3/4-16 Str. Thd.	3/4-16 Str. Thd.	-
T	V20	3/4-16 Str. Thd.	7/8-14 Str. Thd.	3/4-16 Str. Thd.	-	-	-
V	V10 & V20	-	-	-	-	-	7/8-14 Str. Thd.

# V10/V20 Series

## Parts Breakdown

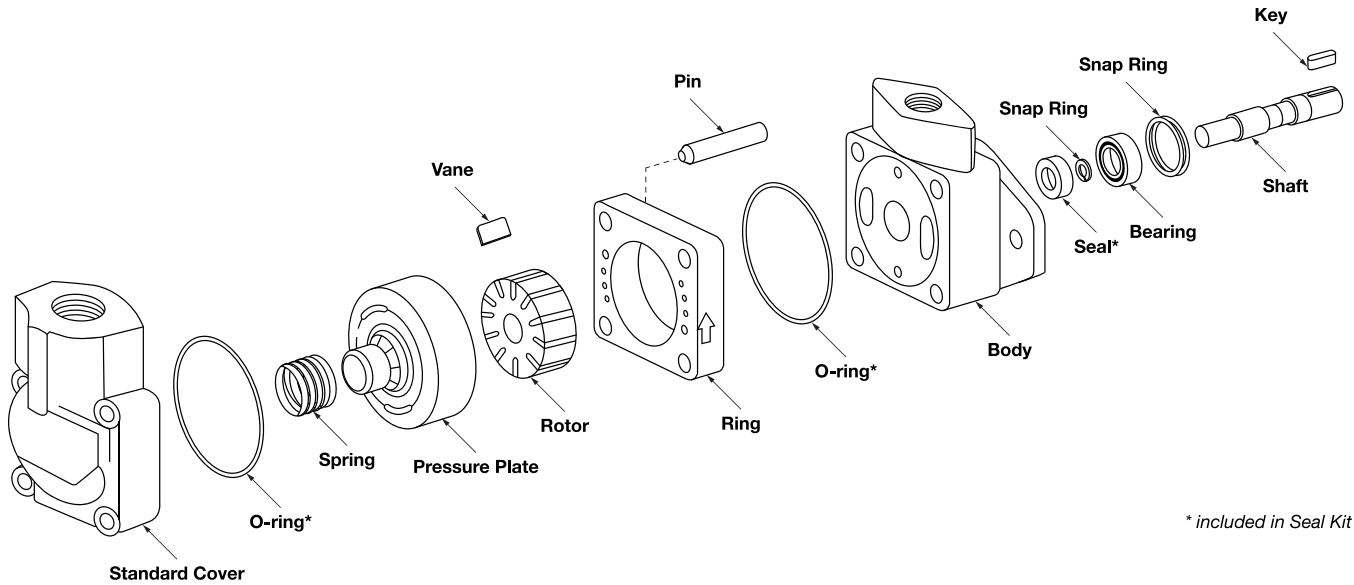

PUMP SERIES	CART KIT	ROTOR	VANES	RING	SEAL	SEAL KIT	BEARING	PR. PL.	SPRING	BODY	COVER	SHAFT NO.	
<b>V10</b>	1	923471	317681	923499	317674	263585	923548	148423	374343	345262	352699	372863	Shaft 1 No. 374338
	2	923470			317675	Viton	Viton						Shaft 3 No. 374340
	3	923496			317676	388205	919772						Shaft 11 No. 374339
	4	923469	351247	923500	317677								Shaft 12 No. 375480
	5	923468			317678								Shaft 38 No. 387481
	6	923497	357268	923501	355641								
	7	923498			331813								
<b>V20</b>	5	924076	358328	923328	388284	229235	922733	098574	359287	28422	280689	313657	Shaft 1 No. 280372
	6	923480			328150	Viton	Viton						Shaft 3 No. 280504
	7	923481	358330	923493	328152	279499	919805						Shaft 6 No. 297330
	8	923483			331791								Shaft 11 No. 280515
	9	923484			331789								Shaft 15 No. 294922
	10	923620	358332	923478	374309								Shaft 38 No. 328096
	11	923482			328156								
	12	923486	358334	923479	331806								
	13	923487			331807								

### Changing Cartridge Rotation

Assemble the ring using the location pins for alignment making sure the arrow on the perimeter points in the proper direction for rotation. Install the rotor on the shaft and insert vanes in the rotor slots. Be certain the radius edges of the vanes are towards the cam ring.

### Rear Cover Bolt Torque

- V10 - 40 ft/lbs (54.2 Nm)
- V20 - 80 ft/lbs (108.5 Nm)

# V10 Series

## Dimensions

Dimensions are in millimeters (inches).

- Weight: 10 - 15 lbs (4.5 - 6.8 kgs)
- Pressure: 1/2" NPT
- Suction: 1" NPT
- Optional BSPT/SAE Ports Available

DELIVERY AT 1200 RPM & 100 PSI	DIMENSIONS	
	X	Y
1 gpm (3.8 lpm)	115.6 (4.55)	91.9 (3.62)
2 gpm (7.6 lpm)	115.6 (4.55)	91.9 (3.62)
3 gpm (11.4 lpm)	115.6 (4.55)	91.9 (3.62)
4 gpm (15.1 lpm)	121.9 (4.80)	98.3 (3.87)
5 gpm (18.9 lpm)	121.9 (4.80)	98.3 (3.87)
6 gpm (22.7 lpm)	127.0 (5.00)	103.4 (4.07)
7 gpm (26.5 lpm)	127.0 (5.00)	103.4 (4.07)

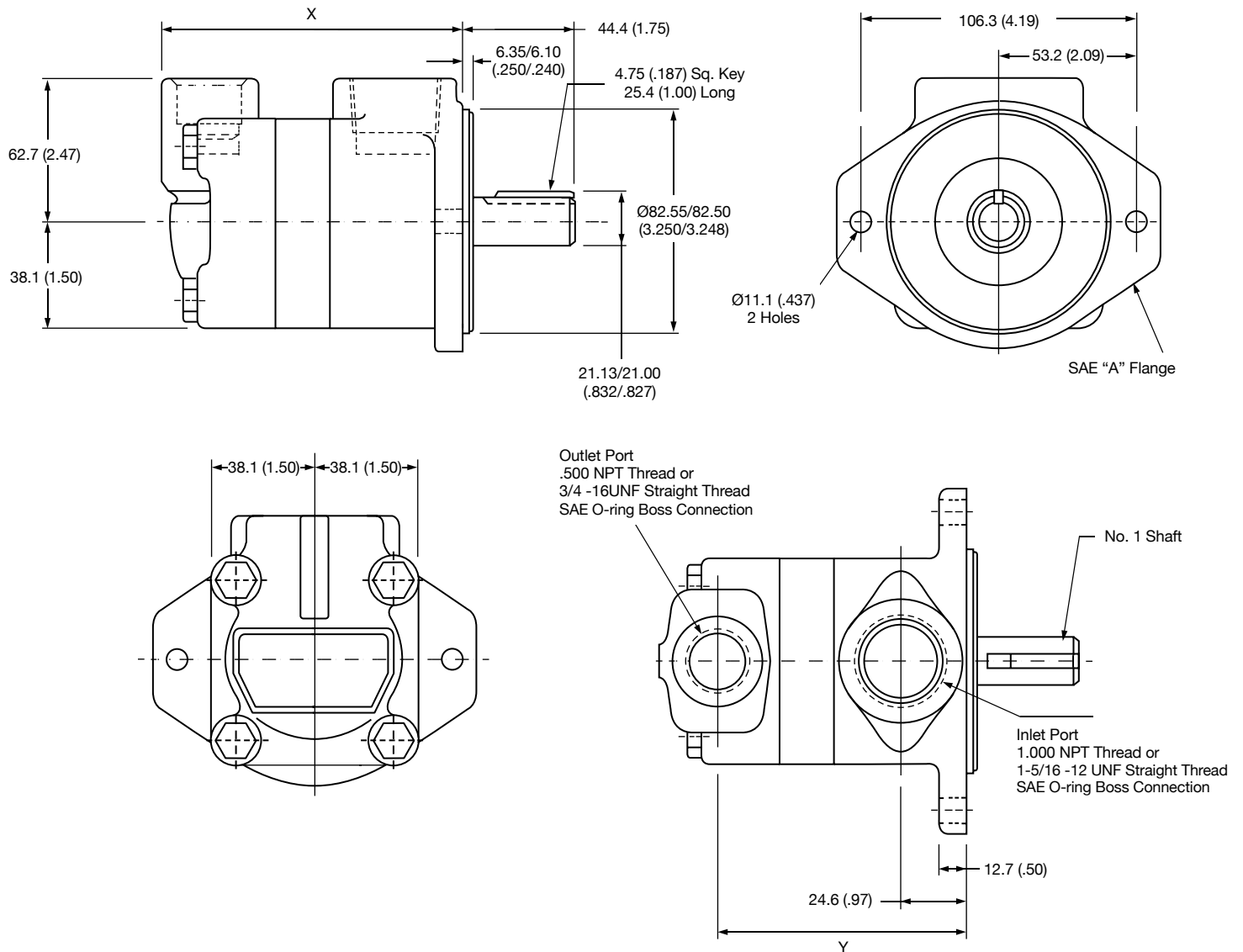

# V20 Series

## Dimensions

Dimensions are in millimeters (inches).

- Weight: 16 - 18 lbs (7.3 - 8.2 kgs)
- Pressure: 3/4" NPT
- Suction: 1-1/4" NPT
- Optional BSPT/SAE Ports Available

DELIVERY AT 1200 RPM & 100 PSI	DIMENSIONS	
	X	Y
6 gpm (22.7 lpm)	125.2 (4.93)	102.1 (4.02)
7 gpm (26.5 lpm)	131.6 (5.18)	108.4 (4.27)
8 gpm (30.3 lpm)	131.6 (5.18)	108.4 (4.27)
9 gpm (34.1 lpm)	131.6 (5.18)	108.4 (4.27)
11 gpm (41.6 lpm)	136.6 (5.38)	113.5 (4.47)
12 gpm (45.4 lpm)	140.2 (5.52)	117.1 (4.61)
13 gpm (49.2 lpm)	140.2 (5.52)	117.1 (4.61)

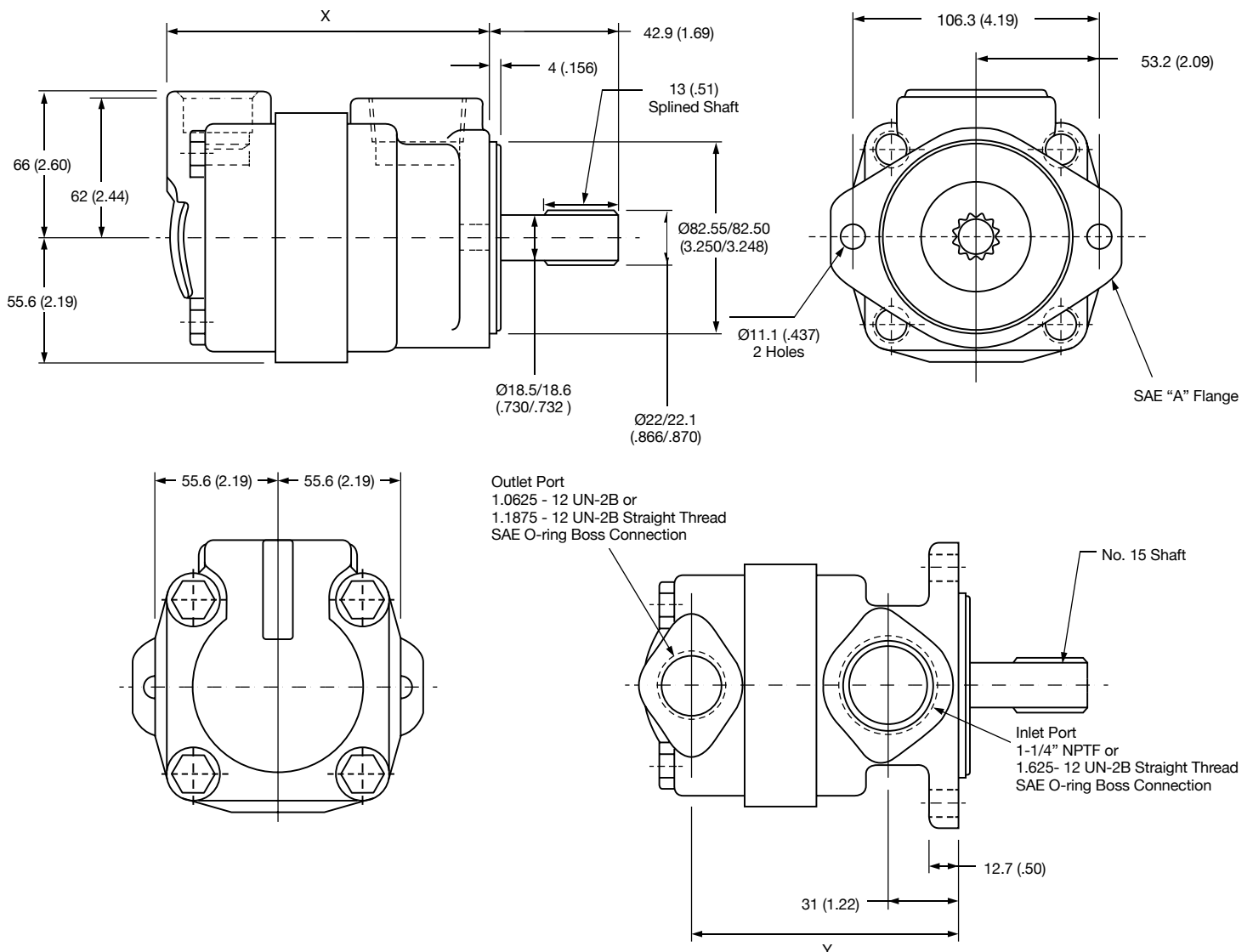



## V10 Series

### Optional Shaft Dimensions

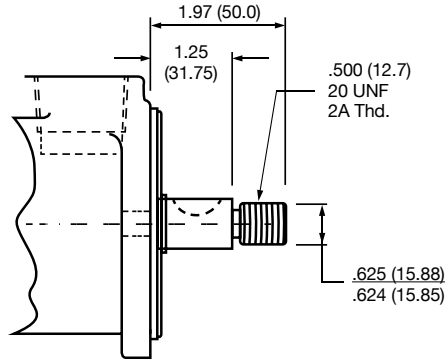

No. 3 Keyed Shaft

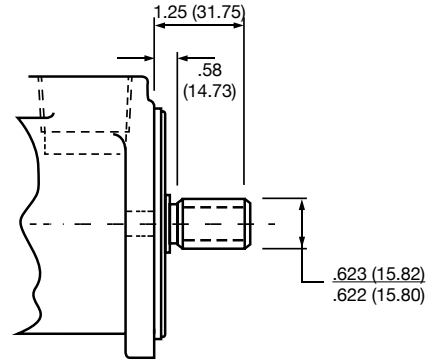

No. 11 Splined Shaft, 9 Tooth

## V20 Series

### Optional Shaft Dimensions

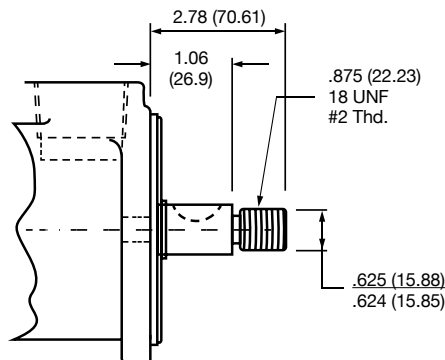

No. 3 Keyed Shaft

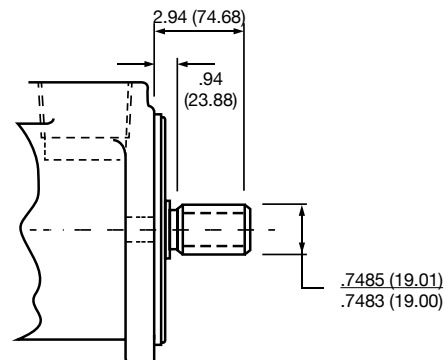

No. 11 Splined Shaft, 9 Tooth

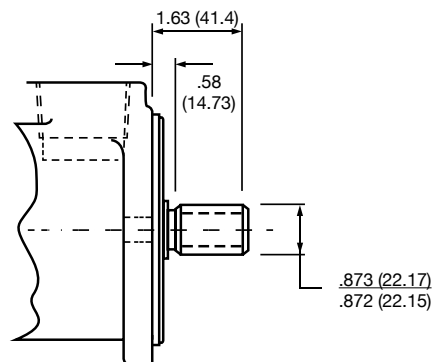

No. 15 Splined Shaft, 13 Tooth

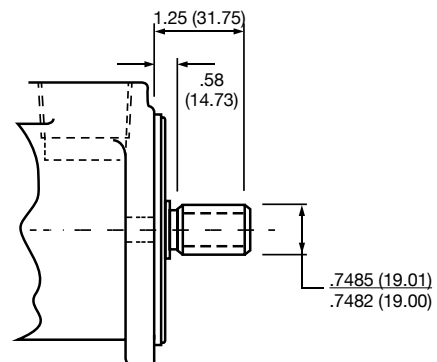

No. 38 Splined Shaft, 11 Tooth

# V10F Series

## Flow Control Valve Dimensions

FLOW RATE ORIFICE	
2	-2 U.S. gpm (7.6 lpm)
3	-3 U.S. gpm (11.4 lpm)
4	-4 U.S. gpm (15.1 lpm)
5	-5 U.S. gpm (18.9 lpm)
6	-6 U.S. gpm (22.7 lpm)
7	-7 U.S. gpm (26.5 lpm)
8	-8 U.S. gpm (30.3 lpm)

RELIEF VALVE NUMBER/PRESSURE SETTING	
A	250 psi (17.2 bar)
B	500 psi (34.5 bar)
C	750 psi (51.7 bar)
D	1000 psi (68.9 bar)
E	1250 psi (86.2 bar)
F	1500 psi (103.4 bar)
G	1750 psi (120.7 bar)
H	2000 psi (137.9 bar)
J	2250 psi (155.1 bar)
K	2500 psi (172.4 bar)

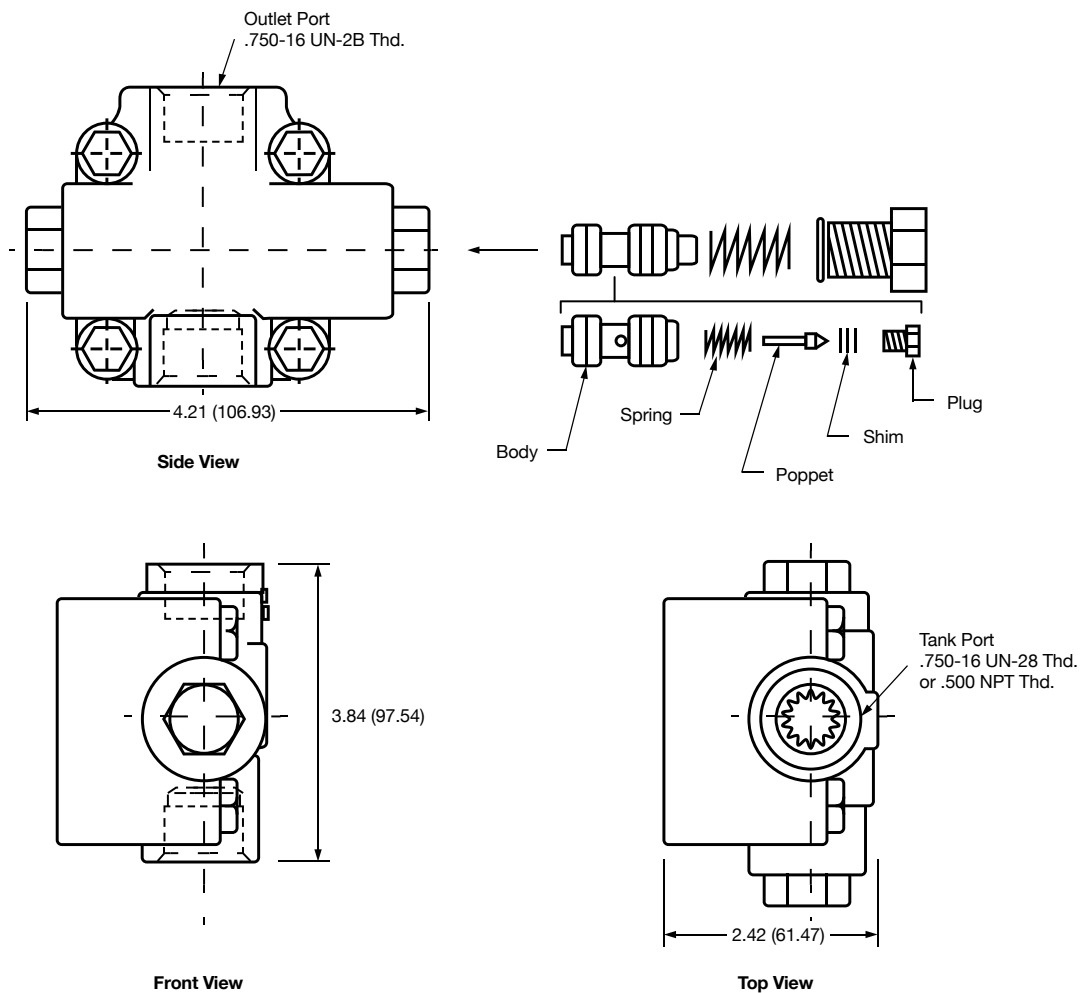

# V20F Series

## Flow Control Valve Dimensions

FLOW RATE ORIFICE	
2	-2 U.S. gpm (7.6 lpm)
3	-3 U.S. gpm (11.4 lpm)
4	-4 U.S. gpm (15.1 lpm)
5	-5 U.S. gpm (18.9 lpm)
6	-6 U.S. gpm (22.7 lpm)
7	-7 U.S. gpm (26.5 lpm)
8	-8 U.S. gpm (30.3 lpm)

RELIEF VALVE NUMBER/PRESSURE SETTING	
A	250 psi (17.2 bar)
B	500 psi (34.5 bar)
C	750 psi (51.7 bar)
D	1000 psi (68.9 bar)
E	1250 psi (86.2 bar)
F	1500 psi (103.4 bar)
G	1750 psi (120.7 bar)
H	2000 psi (137.9 bar)
J	2250 psi (155.1 bar)
K	2500 psi (172.4 bar)

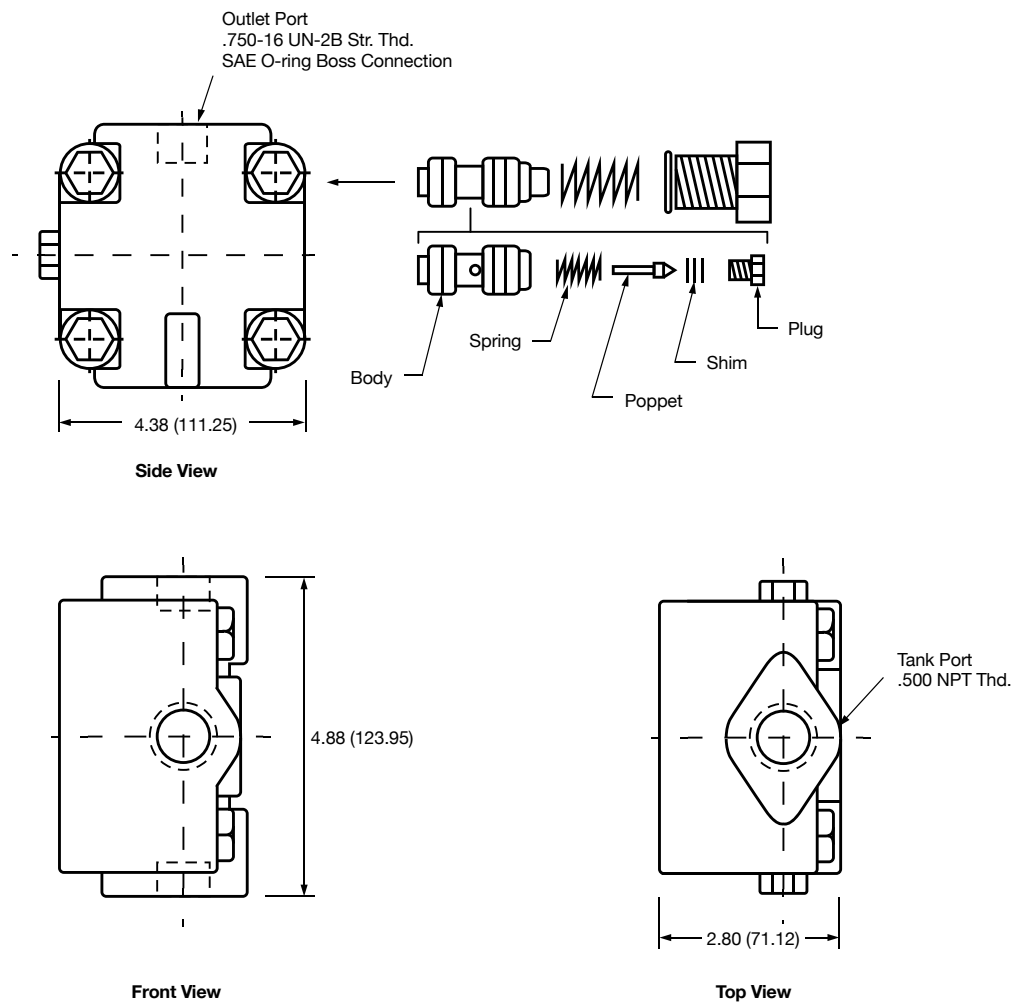

# V10/V20 Series

## Priority Covers

FLOW RATE ORIFICE	
2	-2 U.S. gpm (7.6 lpm)
3	-3 U.S. gpm (11.4 lpm)
4	-4 U.S. gpm (15.1 lpm)
5	-5 U.S. gpm (18.9 lpm)
6	-6 U.S. gpm (22.7 lpm)
7	-7 U.S. gpm (26.5 lpm)
8	-8 U.S. gpm (30.3 lpm)

RELIEF VALVE NUMBER/PRESSURE SETTING	
A	250 psi (17.2 bar)
B	500 psi (34.5 bar)
C	750 psi (51.7 bar)
D	1000 psi (68.9 bar)
E	1250 psi (86.2 bar)
F	1500 psi (103.4 bar)
G	1750 psi (120.7 bar)
H	2000 psi (137.9 bar)
J	2250 psi (155.1 bar)
K	2500 psi (172.4 bar)

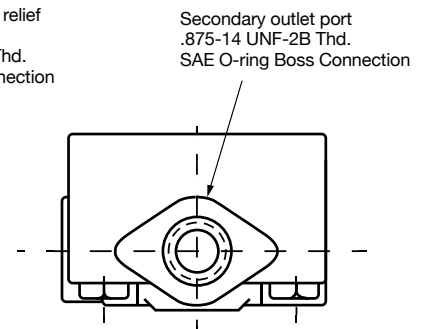
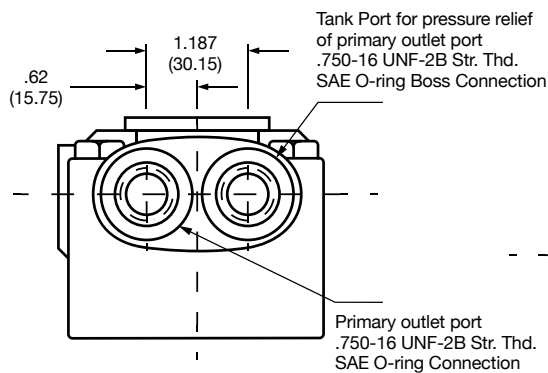
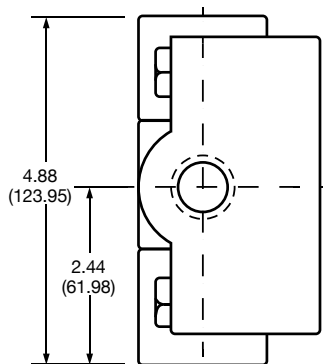
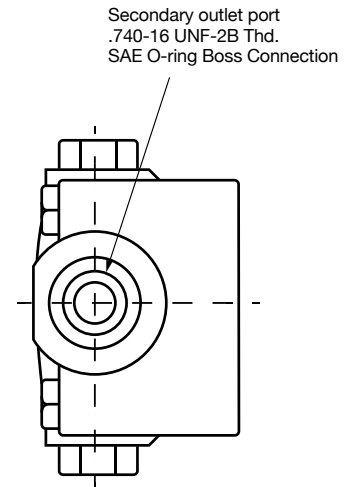
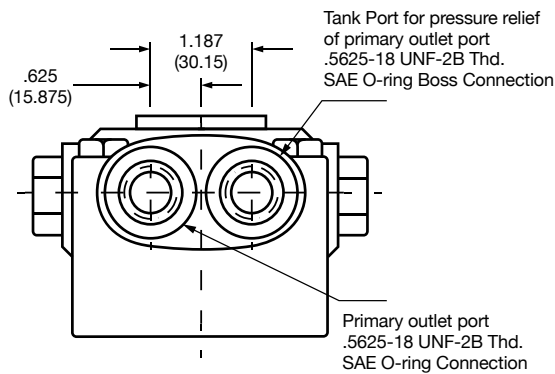
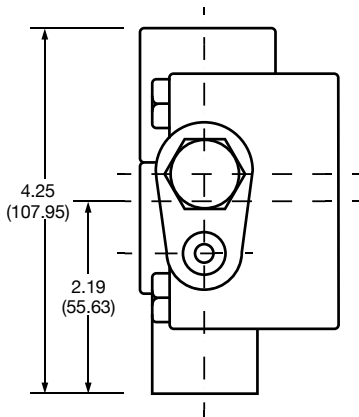

## V10/V20 Series

### Optional Port Position

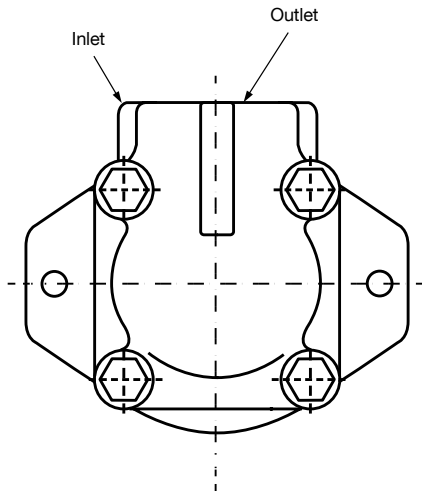

C - In-line with Inlet

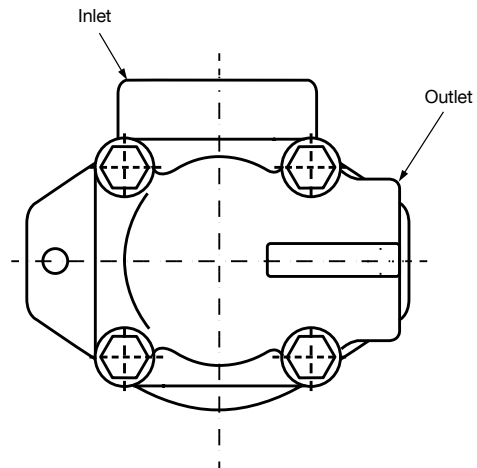

D - 90° Clockwise from Inlet

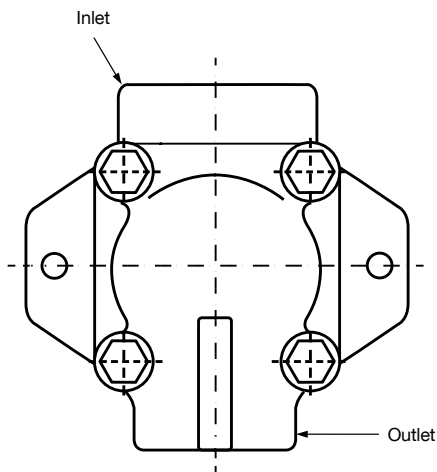

A - Opposite of Inlet

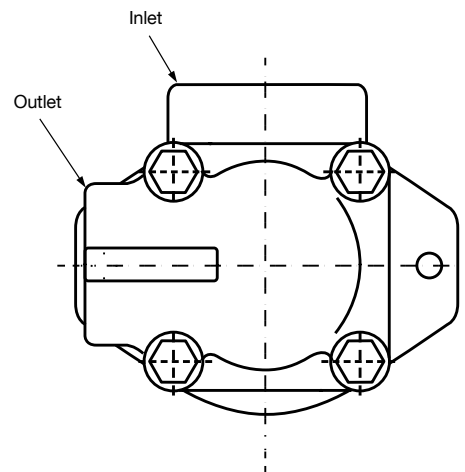

B - 90° Counter-Clockwise from Inlet

### Rear Cover Bolt Torque

- V10 - 40 ft/lbs (54.2 Nm)
- V20 - 80 ft/lbs (108.5 Nm)

**Note:** Remove rear cover bolts and rotate cover for proper port position.

# V10NF Series

## Model Code Breakdown

**V10 - NF - 1 - S - 8 - T - 38 - A - 4 - D - L**

### Vane Pump Series

V10 = Model Series

### Series

NF = Series

### Pump Mounting

1 = 2 Bolt Flange 3.25 Pilot

### Inlet Port Connections

P = 1.25" NPT Pipe Thd. Connection  
S = 1.625" - 12 Straight Thd. Connection

### Ring Capacity in U.S. gpm

All values rated at 1200 rpm

#### V10 Size

- 2 = 2 gpm (7.6 lpm)
- 3 = 3 gpm (11.4 lpm)
- 4 = 4 gpm (15.1 lpm)
- 5 = 5 gpm (18.9 lpm)
- 6 = 6 gpm (23.1 lpm)
- 7 = 7 gpm (27.2 lpm)

### Flow Control Cover

T = Pressure port .75" -16 Str. Thd.

### Shaft Rotation

\* = Omit for Right-hand (Clockwise) Rotation

L = Left-hand (Counter-Clockwise) Rotation

### Pressure Setting

- C = 750 psi (51.7 bar)
- D = 1000 psi (68.9 bar)
- E = 1250 psi (86.2 bar)
- F = 1500 psi (103.4 bar)
- G = 1750 psi (120.6 bar)
- H = 2000 psi (137.9 bar)
- J = 2250 psi (155.1 bar)
- K = 2500 psi (172.4 bar)
- L = 2750 psi (189.6 bar)

### Flow Rate Through Orifice in Cover

- 2 = 2 gpm (7.6 lpm)
- 3 = 3 gpm (11.4 lpm)
- 4 = 4 gpm (15.1 lpm)
- 5 = 5 gpm (18.9 lpm)

### Position of Primary Outlet Port

- A = Opposite Inlet Port (Viewed from Cover End of Pump)
- B = 90° CCW from Inlet (Viewed from Cover End of Pump)
- C = Inline with Inlet Port (Viewed from Cover End of Pump)
- D = 90° CW from Inlet (Viewed from Cover End of Pump)

### Shafts

- 1 = Standard Straight Keyed
- 3 = Threaded
- 6 = Straight Stub
- 10 = Threaded Stub
- 11 = Splined
- 38 = Splined

# V10NF Series

## Parts Breakdown

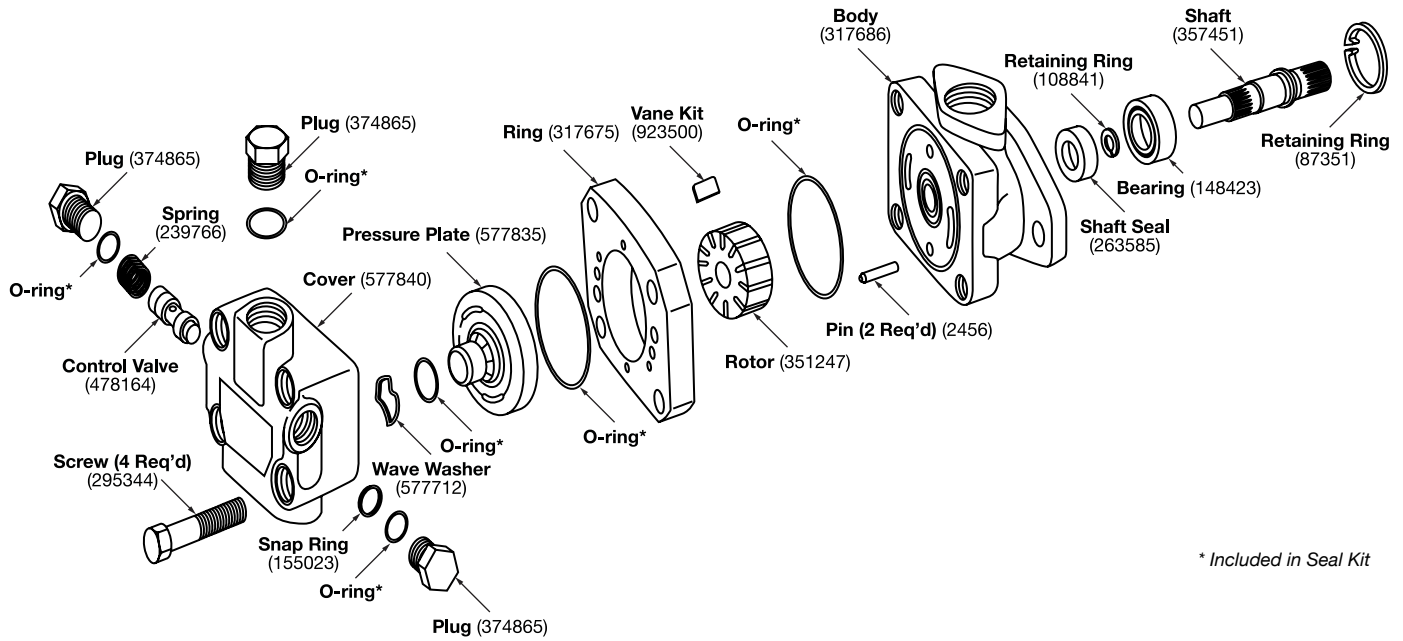

PUMP SERIES	CART KIT	ROTOR	VANES	RING	SEAL	SEAL KIT	BEARING	PR. PL.	SPRING	BODY	COVER	SHAFT NO.	
V10NF	2	923470	351247	923500	317675	263585	920372	148423	577835	239766	317686	577840	Shaft 1 No. 374338
	3	923496		317676	388205	919772							Shaft 3 No. 374340
	4	923469	351247	923500	317677								Shaft 11 No. 374339
	5	923468		317678									Shaft 12 No. 375480
	6	923497	357268	923501	355641								Shaft 38 No. 387481
	7	923498		331813									

## Rear Cover Bolt Torque

- V10 - 40 ft/lbs (54.2 Nm)
- V20 - 80 ft/lbs (108.5 Nm)

# V20NF Series

## Model Code Breakdown

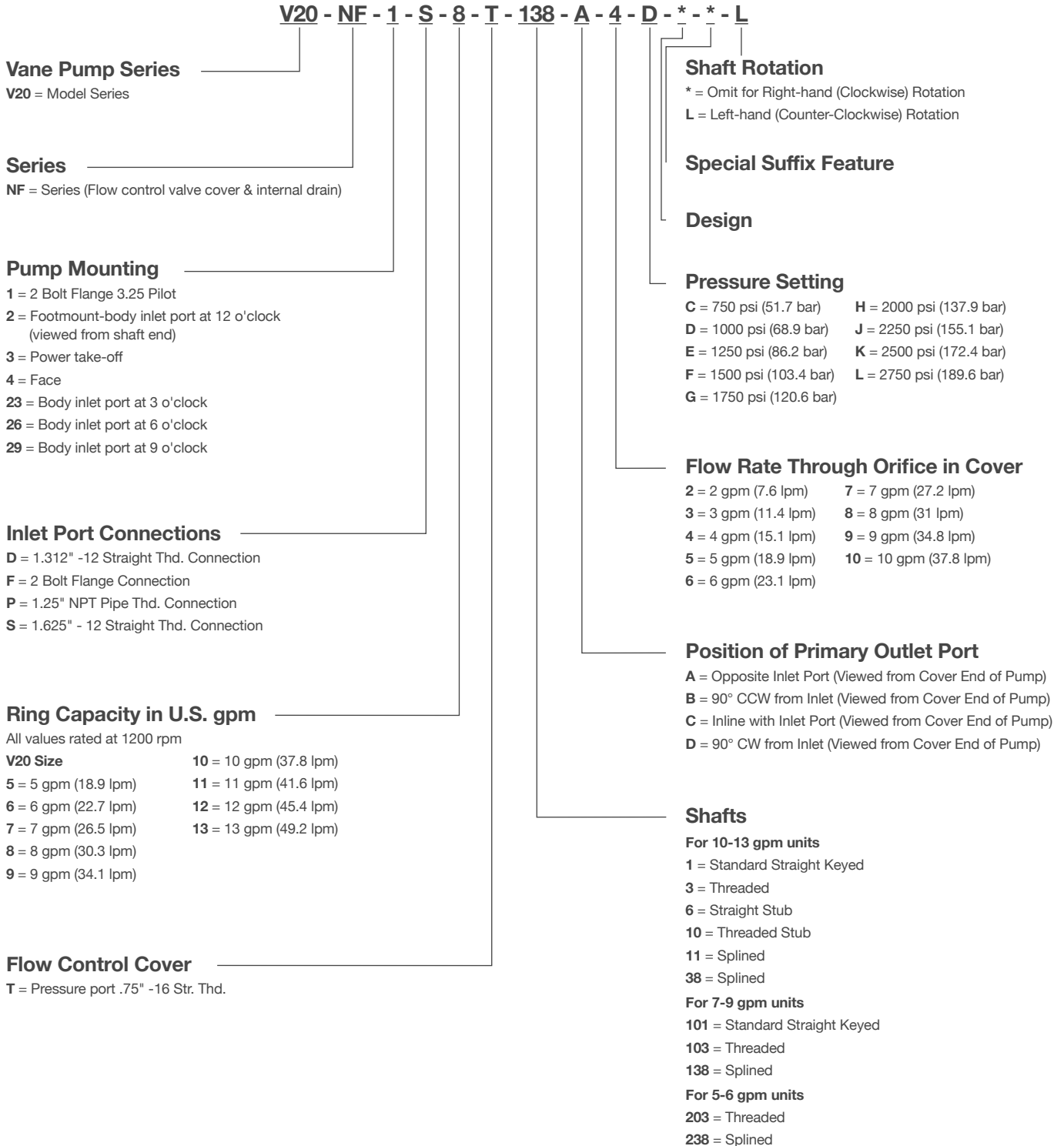



# V20NF Series

## Parts Breakdown

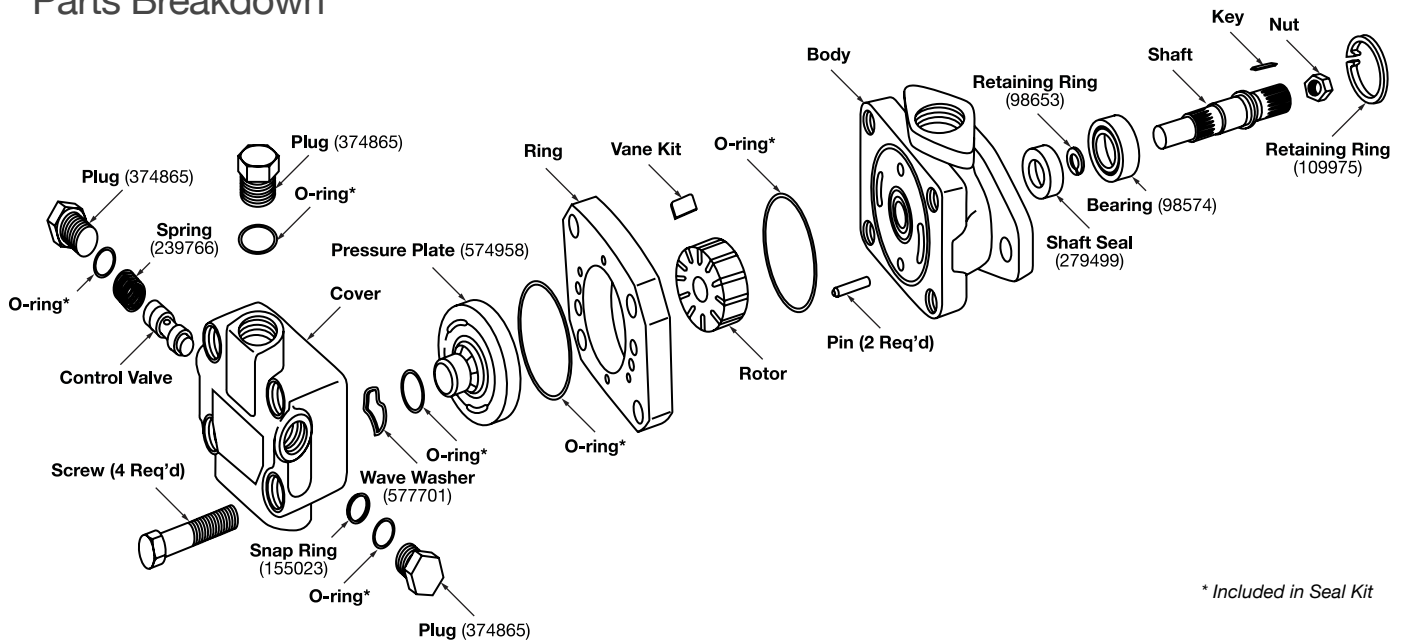

MODEL	BODY
V20NF-***T-***C-22	232794
V20NF-***T-***D-22	232795
V20NF-***T-***E-22	232796
V20NF-***T-***F-22	232797
V20NF-***T-***G-22	232798
V20NF-***T-***H-22	232799
V20NF-***T-***J-22	233019
V20NF-***T-***K-22	233020
V20NF-***T-***L-22	266200

MODEL	BODY
V20NF-1D	583170
V20NF-4D	583172
V20NF-1F	297228
V20NF-1P	280689
V20NF-4P	308628
V20NF-1S	294266

MODEL	BODY
V20NF-***T-***2*-22	452272
V20NF-***T-***3*-22	452240
V20NF-***T-***4*-22	452242
V20NF-***T-***5*-22	452069
V20NF-***T-***6*-22	452244
V20NF-***T-***7*-22	574959
V20NF-***T-***8*-22	452071
V20NF-***T-***9*-22	478133
V20NF-***T-***10*-22	452747

MODEL	SHAFT	KEY	NUT
V20NF-***T-1	280372	5881	-
V20NF-***T-3	280504	1615	132260
V20NF-***T-6	297330	1609	-
V20NF-***T-10	324042	1609	-
V20NF-***T-11	280515	-	-
V20NF-***T-38	328096	-	-
V20NF-***T-101	478142	5881	-
V20NF-***T-103	478136	1615	132260
V20NF-***T-138	478122	-	-
V20NF-***T-203	502682	1615	132260
V20NF-***T-238	502235	-	-

MODEL	PIN	SCREW	VANE KIT	RING & RTR	CART KIT
V20NF-***5T	2161	11165	923651	503157	923656
V20NF-***6T	2161	11165	923651	452235	923657
V20NF-***7T	2478	9431	923652	452261	923658
V20NF-***8T	2478	9431	923652	574954	923659
V20NF-***9T	2478	9431	923652	452264	923660
V20NF-***10T	16662	96168	923653	452267	923661
V20NF-***11T	16662	96168	923653	574945	923662
V20NF-***12T	9603	96168	923654	452270	923663
V20NF-***13T	9603	96168	923654	452245	923664

# V2010/V2020 Series

## Features

Balanced vane type pumps are excellent for medium- to low-pressure mobile and industrial applications. Available with integrated flow control valves to simplify system design and installation, these pumps are commonly used as pilot and auxiliary pumps for complex systems, and on heavy-duty trucks and interstate buses. Compact size and ease of service allow maximum equipment design flexibility.

- High Performance
- Pressure-balanced
- Low Cost/Economical
- Engineered for Extended Life
- Versatile and Low Noise
- Compact
- Weight: 30-35 lbs (13.6 - 15.9 kgs)

## Specifications

PUMP	SHAFT END FLOW IN GPM @ 1200 RPM & 100 PSI	DISPL. IN <sup>3</sup> /R (CM <sup>3</sup> /R)	MAX. SPEED (RPM)	MAX. PRESSURE PSI (BAR)	TYP. DELIVERY GPM @ MAX. SPEED & PRESSURE (LPM)	TYPICAL INPUT POWER HP @ MAX. SPEED & PRESS. (KW)	COVER END FLOW IN GPM @ 1200 RPM & 100 PSI	DISPL. IN <sup>3</sup> /R (CM <sup>3</sup> /R)	MAX. SPEED (RPM)	MAX. PRESSURE PSI (BAR)	TYP. DELIVERY GPM @ MAX. SPEED & PRESSURE (LPM)	TYPICAL INPUT POWER HP @ MAX. SPEED & PRESS. (KW)
<b>V2010</b>	6	1.19 (19.5)	3000	2500 (172)	14.5 (54.9)	24.5 (18.3)	1	.20 (3.3)	3000	2500 (172)	2 (7.6)	4.5 (3.4)
	7	1.39 (22.8)	3000	2500 (172)	16.5 (62.5)	30 (22.4)	2	.40 (6.6)	3000	2500 (172)	4.7 (17.8)	9 (6.7)
	8	1.62 (26.5)	2800	2500 (172)	17.5 (66.2)	32.5 (24.2)	3	.60 (9.8)	3000	2500 (172)	7 (26.5)	13.4 (10)
	9	1.81 (29.7)	2800	2500 (172)	20 (75.7)	36 (26.8)	4	.80 (13.1)	3000	2500 (172)	9.5 (36)	18 (13.4)
	11	2.22 (36.4)	2500	2500 (172)	23 (87.1)	37.5 (28)	5	1.00 (16.4)	3000	2500 (172)	12 (45.4)	21.5 (16)
	12	2.38 (39)	2400	2200 (152)	23 (87.1)	36 (26.8)	6	1.19 (19.5)	3000	2200 (152)	14.5 (54.9)	24.5 (18.3)
	13	2.59 (42.4)	2400	2200 (152)	26 (98.4)	39 (29.1)	7	1.39 (22.8)	2800	2000 (138)	16 (60.6)	24 (17.9)
<b>V2020</b>	6	1.19 (19.5)	3000	2500 (172)	14.5 (54.9)	24.5 (18.3)	6	1.19 (19.5)	3000	2500 (172)	14.5 (54.9)	24.5 (18.3)
	7	1.39 (22.8)	3000	2500 (172)	16.5 (62.5)	30 (22.4)	7	1.39 (22.8)	3000	2500 (172)	16.5 (62.5)	30 (22.4)
	8	1.62 (26.5)	2800	2500 (172)	17.5 (66.2)	32.5 (24.2)	8	1.62 (26.5)	2800	2500 (172)	17.5 (66.2)	32.5 (24.2)
	9	1.81 (29.7)	2800	2500 (172)	20 (75.7)	36 (26.8)	9	1.81 (29.7)	2800	2500 (172)	20 (75.7)	36 (26.8)
	11	2.22 (36.4)	2500	2500 (172)	23 (87.1)	37.5 (28)	11	2.22 (36.4)	2500	2500 (172)	23 (87.1)	37.5 (28)
	12	2.38 (39)	2400	2200 (152)	23 (87.1)	36 (26.8)						
	13	2.59 (42.4)	2400	2200 (152)	26 (98.4)	39 (29.1)						

Values based on using anti-wear type petroleum oil 150 SUS at 100° F (ISO rating of 32 cSt at 38° C) and 0 psi inlet pressure.

# V2010 Series

## Model Code Breakdown

### Special Note

Place an **F3** in front of the model code for **Special Seals**.

Example: F3-V-2010-\* -1-\* -F-8-S-1-P-1-\*\*-12-L

**V - 2010 - \* - 1 - \* - F - 8 - S - 1 - P - 1 - \*\* - 12 - L**

### Vane Pump Series

V = Vane Pump Series

### Series

2010 = Series Designation

### Cover Type

\* = Omit for standard cover  
F = Flow control cover  
P = Priority valve cover

### Pump Mounting

1 = 2 Bolt Flange SAE 'B' size  
2 = Foot bracket

### Foot Bracket

(Mounting position with respect to inlet port position when viewed from the shaft end)

3 = Inlet port position at 3 o'clock  
6 = Inlet port position at 6 o'clock  
9 = Inlet port position at 9 o'clock  
\* = Omit for Inlet port position at 12 o'clock

### Inlet Port Connections

F = 4 Bolt Flange 1.5" diam. SF

### Ring Capacity in U.S. gpm (Shaft end)

All values rated at 1200 rpm & 100 psi

7 = 7 gpm (26.5 lpm)    11 = 11 gpm (41.6 lpm)  
8 = 8 gpm (30.3 lpm)    12 = 12 gpm (45.4 lpm)  
9 = 9 gpm (34.1 lpm)    13 = 13 gpm (49.2 lpm)

### Outlet Port

(Shaft end)

S = 1.062"-12 UN 2B Thd. Connection  
B = G 3/4"

### Ring Capacity in U.S. gpm (Cover end)

All values rated at 1200 rpm & 100 psi

1 = 1 gpm (3.8 lpm)    5 = 5 gpm (18.9 lpm)  
2 = 2 gpm (7.6 lpm)    6 = 6 gpm (22.7 lpm)  
3 = 3 gpm (11.4 lpm)    7 = 7 gpm (26.5 lpm)  
4 = 4 gpm (15.1 lpm)

### Shaft Rotation

(Viewed from shaft end)

\* = Omit for Right-hand (Clockwise) Rotation  
L = Left-hand (Counter-Clockwise) Rotation

### Design

### Outlet Port Position

(Viewed from rear cover end of pump)

**With No. 1 Outlet (shaft end) opposite inlet port**

AA = No. 2 Outlet 135° CCW from inlet  
AB = No. 2 Outlet 45° CCW from inlet  
AC = No. 2 Outlet 45° CW from inlet  
AD = No. 2 Outlet 135° CW from inlet

**With No. 1 Outlet (shaft end) 90° CCW from inlet port**

BA = No. 2 Outlet 135° CCW from inlet  
BB = No. 2 Outlet 45° CCW from inlet  
BC = No. 2 Outlet 45° CW from inlet  
BD = No. 2 Outlet 135° CW from inlet

**With No. 1 Outlet (shaft end) inline with inlet port**

CA = No. 2 Outlet 135° CCW from inlet  
CB = No. 2 Outlet 45° CCW from inlet  
CC = No. 2 Outlet 45° CW from inlet  
CD = No. 2 Outlet 135° CW from inlet

**With No. 1 Outlet (shaft end) 90° CW from inlet port**

DA = No. 2 Outlet 135° CCW from inlet  
DB = No. 2 Outlet 45° CCW from inlet  
DC = No. 2 Outlet 45° CW from inlet  
DD = No. 2 Outlet 135° CW from inlet

### Shafts

1 = Straight keyed  
3 = Threaded w/ woodruff key  
11 = Splined 13 tooth

### Outlet Port Connections

(Cover end)

Code	Std. Cover	Flow Control Cover	
		Pressure	Tank
B	G 1/2"	-	-
P	1/2" NPT	3/4" St. Thd.	1/2" NPT
R	1.062 - 12 St. Thd.	-	-
S	3/4" St. Thd.	-	-
T	-	3/4" St. Thd.	3/4" St. Thd.

# V2010 Series - Double Vane Pump

## Parts Breakdown

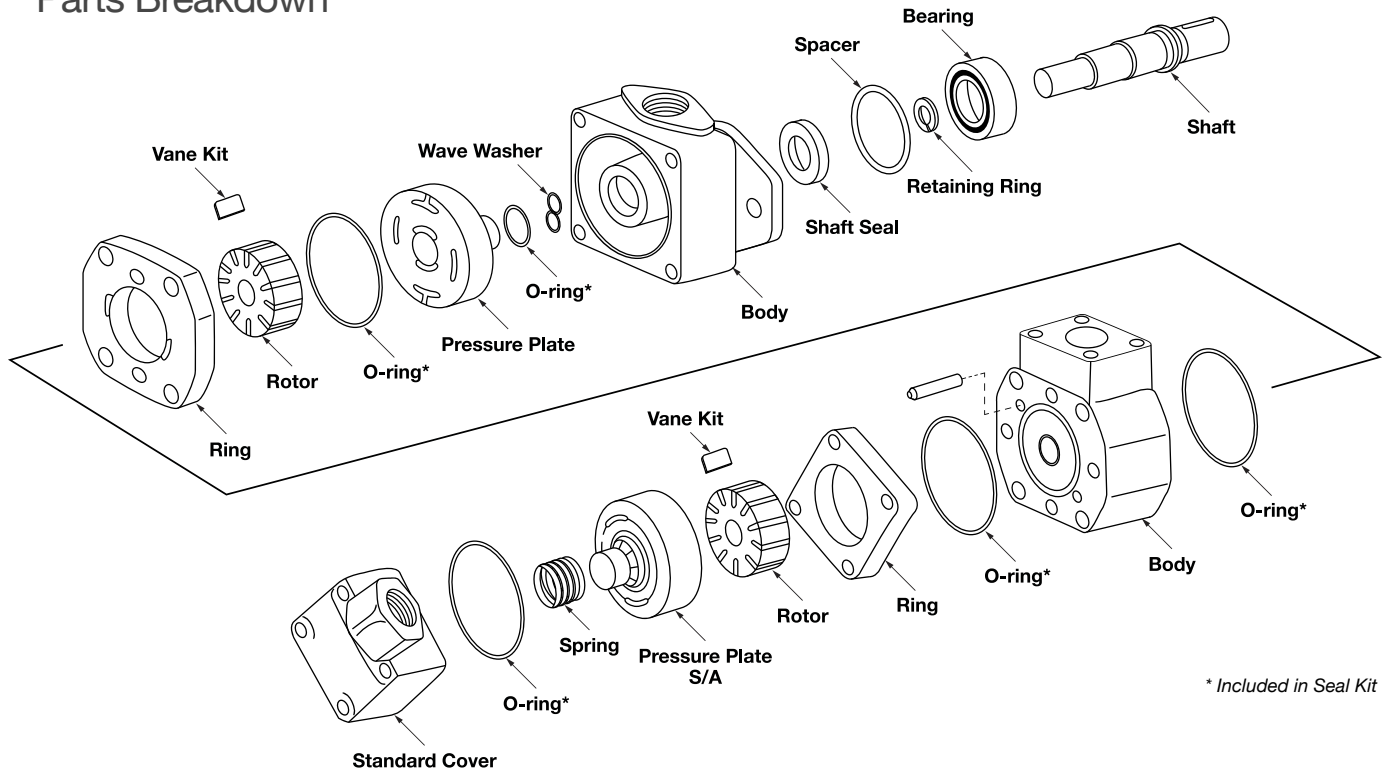

PUMP	FRONT CART. KIT	FRONT ROTOR	FRONT VANE	FRONT RING	FRONT PRES. PLT.	BACK CART. KIT	BACK ROTOR	BACK VANE	BACK RING	BACK PRES. PLT.	
V2010	6	923474	358339	923493	328152	1	923471		317674		
	7	923494			328152	2	923470	317681	923499	317675	
	8	923495	358335	923493	331791	3	923496		317676		
	9	923462			331789	358347	4	923469	351247	923500	317677
	11	923475	358336	923478	328156		5	923468		317678	
	12	923476			331806		6	923497		355641	
	13	923477	358337	923479	331807		7	923498	357286	923501	331813

PUMP	SEAL KIT	SEAL	BEARING	BODY	SHAFT NO.
V2010	923577	229236	82938	357292	SHAFT 1 - 351249
					SHAFT 11 - 321215

### Changing Cartridge Rotation

Assemble the ring using the location pins for alignment making sure the arrow on the perimeter points in the proper direction for rotation. Install the rotor on the shaft and insert vanes in the rotor slots. Be certain the radius edges of the vanes are towards the cam ring.

### Front Section Bolt Torque

- V2010 - 85 ft/lbs (115.2 Nm)

### Back Section Bolt Torque

- V2010 - 45 ft/lbs (61 Nm)

# V2010 Series - Double Vane Pump

## Dimensions

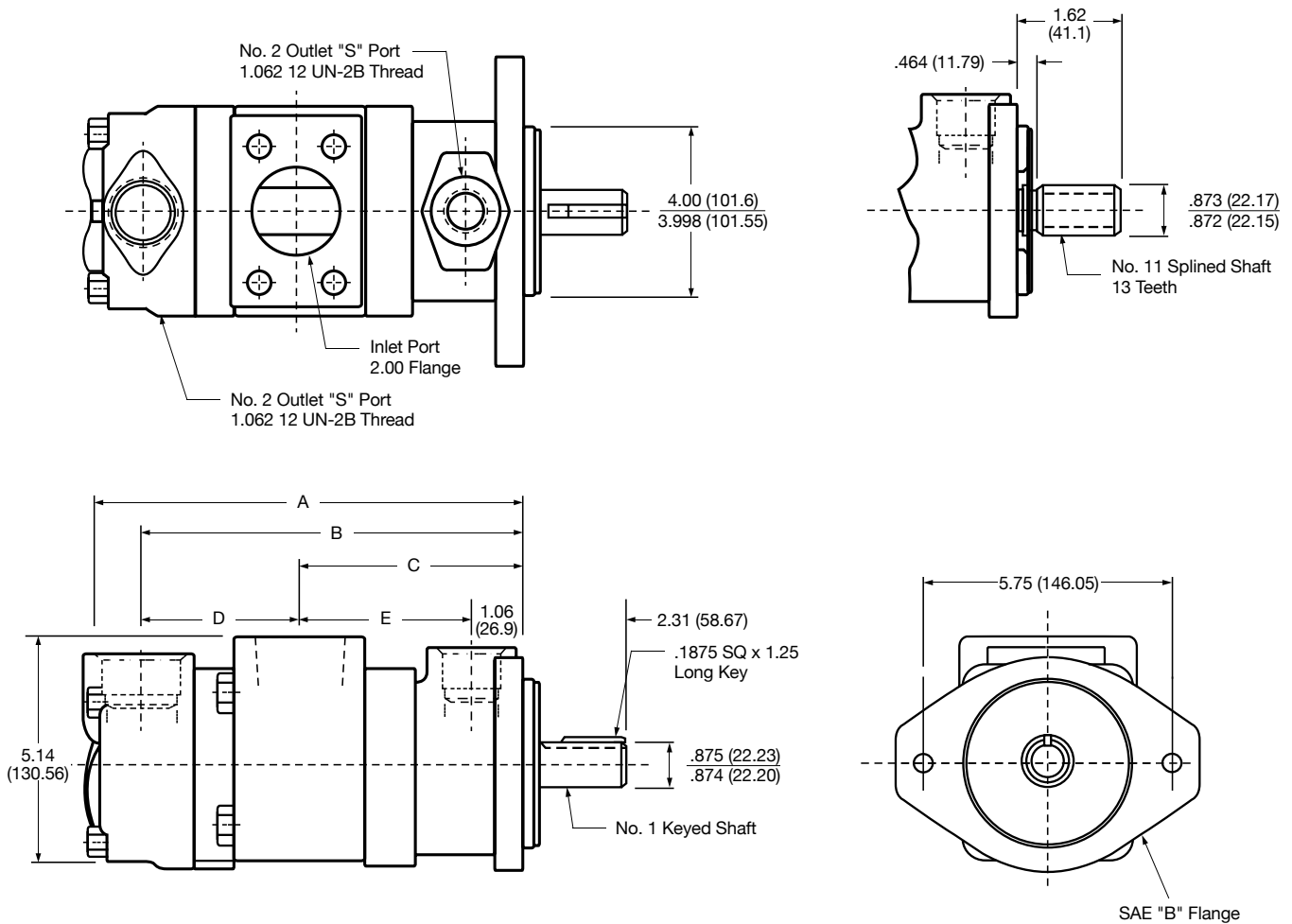

DELIVERY AT 1200 RPM & 100 PSI (7 BAR)		DIMENSIONS				
SHAFT END	COVER END	A	B	C	D	E
7, 8 or 9	1, 2 or 3	8.39 (213.1)	7.45 (189.2)	4.46 (113.3)	2.99 (75.9)	3.40 (86.4)
7, 8 or 9	4 or 5	8.64 (219.5)	7.70 (195.6)	4.46 (113.3)	3.24 (82.3)	3.40 (86.4)
7, 8 or 9	6 or 7	8.84 (224.5)	7.90 (200.7)	4.46 (113.3)	3.44 (87.4)	3.40 (86.4)
11	1, 2 or 3	8.59 (218.2)	7.65 (194.3)	4.65 (118.1)	2.99 (75.9)	3.59 (91.2)
11	4 or 5	8.84 (224.5)	7.90 (200.7)	4.65 (118.1)	3.24 (82.3)	3.59 (91.2)
11	6 or 7	9.04 (229.6)	8.10 (205.7)	4.65 (118.1)	3.44 (87.4)	3.59 (91.2)
12 or 13	1, 2 or 3	8.73 (221.7)	7.79 (197.9)	4.79 (121.7)	2.99 (75.9)	3.73 (94.7)
12 or 13	4 or 5	8.97 (227.8)	8.03 (204.0)	4.79 (121.7)	3.24 (82.3)	3.73 (94.7)
12 or 13	6 or 7	8.23 (209.0)	8.03 (204.0)	4.79 (121.7)	3.44 (87.4)	3.73 (94.7)

# V2020 Series

## Model Code Breakdown

**Special Note**

Place an **F3** in front of the model code for **Special Seals**.  
Example: F3-V-2020-\* -1-\* -F-8-S-9-P-1-\*\*-12-A-30-L

**V - 2020 - \* - 1 - \* - F - 8 - S - 9 - P - 1 - \*\* - 12 - A - 30 - L**

**Vane Pump Series**

V = Vane Pump Series

**Series**

2020 = Series Designation

**Cover Type**

\* = Omit for standard cover  
F = Flow control cover  
P = Priority valve cover

**Pump Mounting**

1 = 2 Bolt Flange SAE 'B' size  
2 = Foot bracket

**Foot Bracket**

(Mounting position with respect to inlet port position when viewed from the shaft end)

3 = Inlet port position at 3 o'clock  
6 = Inlet port position at 6 o'clock  
9 = Inlet port position at 9 o'clock  
\* = Omit for Inlet port position at 12 o'clock

**Inlet Port Connections**

F = 4 Bolt Flange 2" diam. SF

**Ring Capacity in U.S. gpm (Shaft end)**

All values rated at 1200 rpm & 100 psi

6 = 6 gpm (22.7 lpm)      11 = 11 gpm (41.6 lpm)  
7 = 7 gpm (28.5 lpm)      12 = 12 gpm (45.4 lpm)  
8 = 8 gpm (30.3 lpm)      13 = 13 gpm (49.2 lpm)  
9 = 9 gpm (34.1 lpm)

**Outlet Port**

(Shaft end)

S = 1.062"-12 UN 2B Thd. Connection  
B = G 3/4"

**Ring Capacity in U.S. gpm (Cover end)**

All values rated at 1200 rpm & 100 psi

6 = 6 gpm (22.7 lpm)      11 = 11 gpm (41.6 lpm)  
7 = 7 gpm (28.5 lpm)      12 = 12 gpm (45.4 lpm)  
8 = 8 gpm (30.3 lpm)      13 = 13 gpm (49.2 lpm)  
9 = 9 gpm (34.1 lpm)

**Outlet Port Connections**

(Cover end)

Code	Std. Cover	Flow Control Cover	
		Pressure	Tank
B	G 3/4"	-	-
P	-	3/4" St. Thd.	1/2" NPT
S	1.062-12 St. Thd.	3/4" NPT	1.062-12 St. Thd.
T	-	3/4" St. Thd.	3/4" St. Thd.

**Shaft Rotation**

(Viewed from shaft end)

\* = Omit for Right-hand (Clockwise) Rotation  
L = Left-hand (Counter-Clockwise) Rotation

**Design**

**Pressure Setting**

A = 250 psi (17.2 bar)      F = 1500 psi (103.4 bar)  
B = 500 psi (34.5 bar)      G = 1750 psi (120.7 bar)  
C = 750 psi (51.7 bar)      H = 2000 psi (137.9 bar)  
D = 1000 psi (68.9 bar)      J = 2250 psi (155.1 bar)  
E = 1250 psi (86.2 bar)      K = 2500 psi (172.4 bar)

**Flow Rate through Orifice in Cover (US gpm)**

**Outlet Port Position**

(Viewed from rear cover end of pump)

**With No. 1 Outlet (shaft end) opposite inlet port**

AA = No. 2 Outlet opposite of inlet  
AB = No. 2 Outlet 90° CCW from inlet  
AC = No. 2 Outlet inline with inlet  
AD = No. 2 Outlet 90° CW from inlet

**With No. 1 Outlet (shaft end) 90° CCW from inlet port**

BA = No. 2 Outlet opposite of inlet  
BB = No. 2 Outlet 90° CCW from inlet  
BC = No. 2 Outlet inline with inlet  
BD = No. 2 Outlet 90° CW from inlet

**With No. 1 Outlet (shaft end) inline with inlet port**

CA = No. 2 Outlet opposite of inlet  
CB = No. 2 Outlet 90° CCW from inlet  
CC = No. 2 Outlet inline with inlet  
CD = No. 2 Outlet 90° CW from inlet

**With No. 1 Outlet (shaft end) 90° CW from inlet port**

DA = No. 2 Outlet opposite of inlet  
DB = No. 2 Outlet 90° CCW from inlet  
DC = No. 2 Outlet inline with inlet  
DD = No. 2 Outlet 90° CW from inlet

**Shafts**

1 = Straight keyed  
3 = Threaded w/ woodruff key  
11 = Splined 13 tooth  
38 = Splined

# V2020 Series - Double Vane Pump

## Parts Breakdown

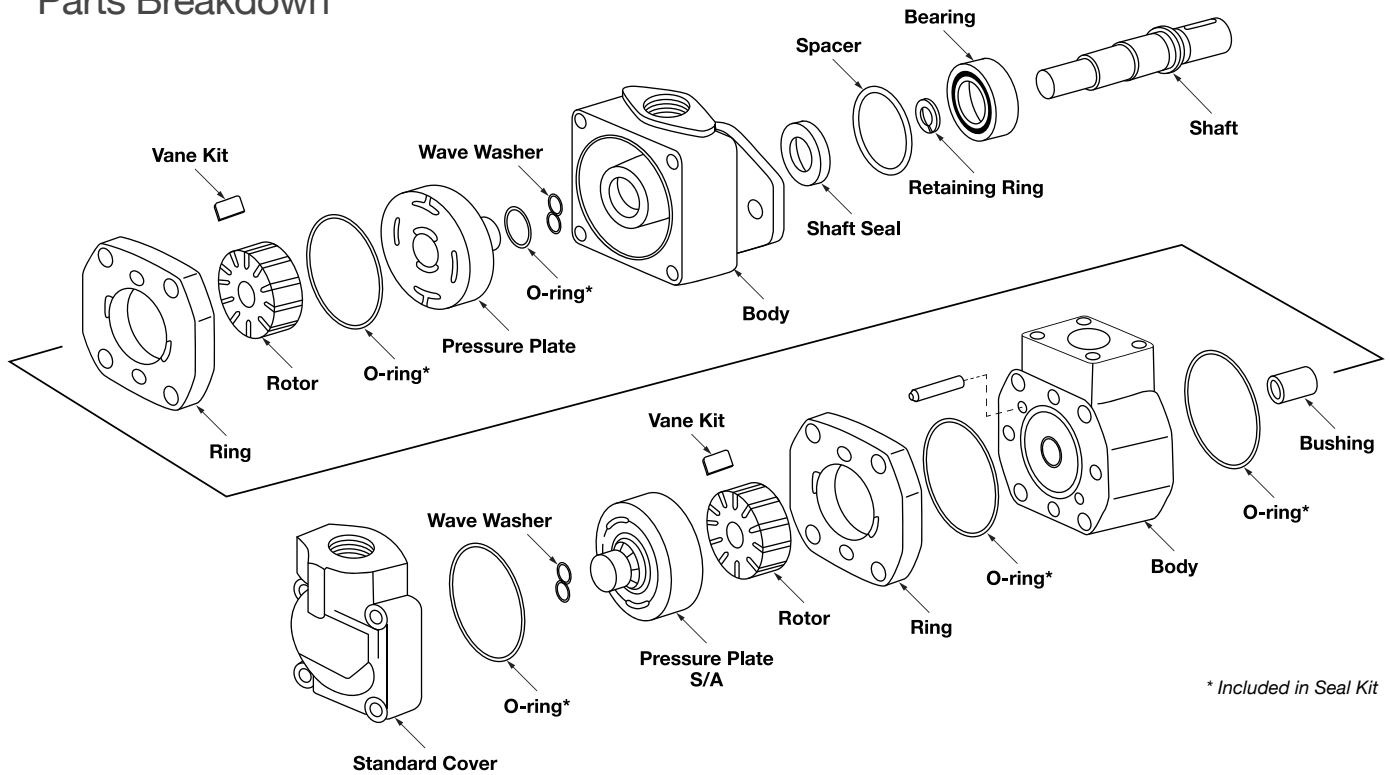

\* Included in Seal Kit

PUMP	FRONT CART. KIT	FRONT ROTOR	FRONT VANE	FRONT RING	FRONT PRES. PLT.	BACK CART. KIT	BACK ROTOR	BACK VANE	BACK RING	BACK PRES. PLT.	
V2020	6	923474	358339	923493	328152	6	923480	358328	923485	328150	
	7	923494			328152	7	923481			328152	
	8	923495	358335	923493	331791	8	923483	358330	923493	331791	358347
	9	923462			331789	358347	9	923484			331789
	11	923475	358336	923478	328156		11	923482	358332	923478	328156
	12	923476			331806						
	13	923477	358337	923479	331807						

PUMP	SEAL KIT	SEAL	BEARING	BODY	SHAFT NO.
V2020	923174	229236	82938	308681	SHAFT 1 - 308686
					SHAFT 11 - 308926

## Changing Cartridge Rotation

Assemble the ring using the location pins for alignment making sure the arrow on the perimeter points in the proper direction for rotation. Install the rotor on the shaft and insert vanes in the rotor slots. Be certain the radius edges of the vanes are towards the cam ring.

## Bolt Torque

- V2020 - 81 ft/lbs (109.8 Nm)

# V2020 Series - Double Vane Pump

## Dimensions

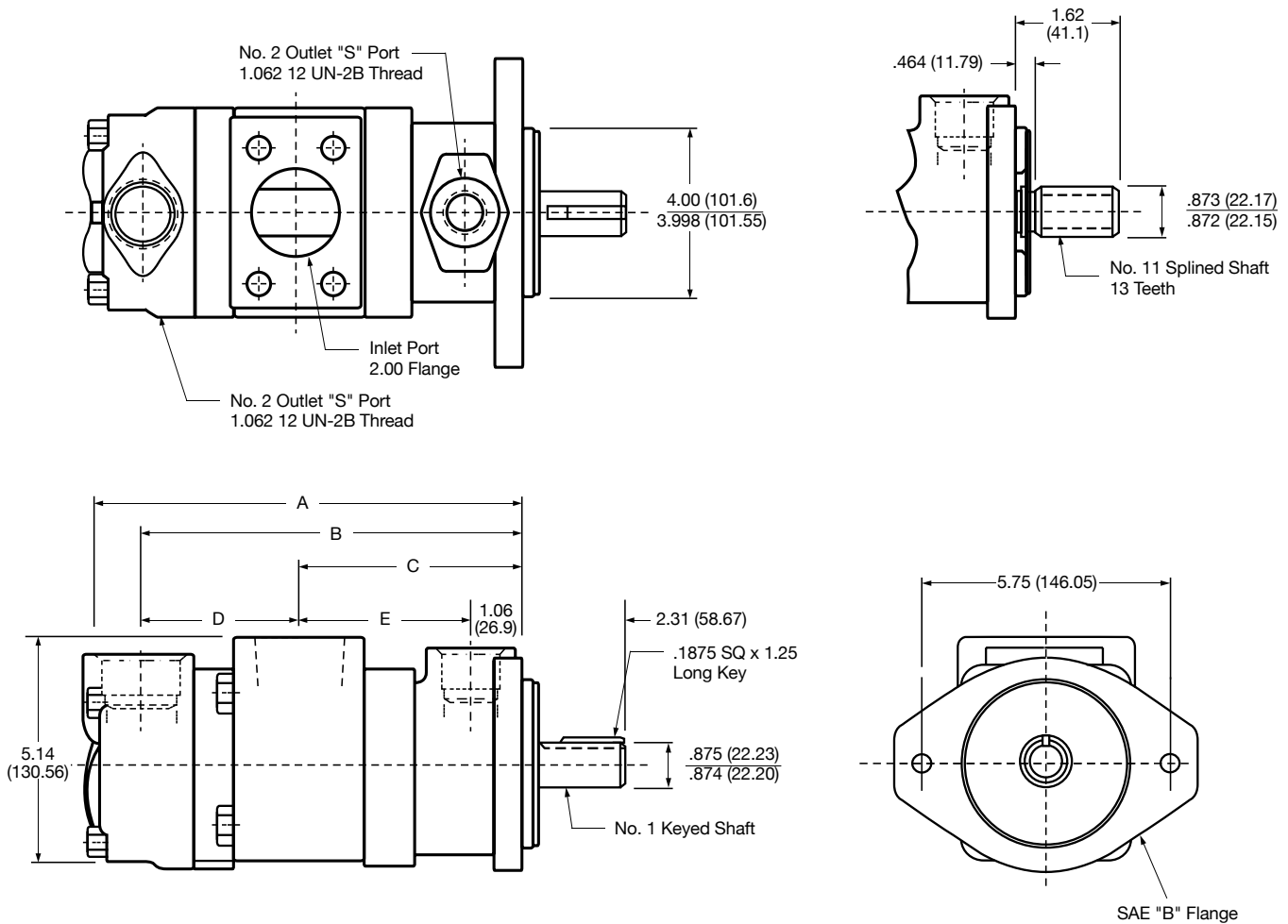

DELIVERY AT 1200 RPM & 100 PSI (7 BAR)		DIMENSIONS				
SHAFT END	COVER END	A	B	C	D	E
7, 8 or 9	6	8.41 (213.6)	7.39 (187.7)	4.49 (114.0)	2.90 (73.7)	3.43 (87.1)
7, 8 or 9	7, 8 or 9	8.66 (220.0)	7.64 (194.1)	4.49 (114.0)	3.15 (80.0)	3.43 (87.1)
11	6	8.61 (218.7)	7.59 (192.8)	4.69 (119.1)	2.90 (73.7)	3.63 (92.2)
11	7, 8 or 9	8.86 (225.0)	7.84 (199.1)	4.69 (119.1)	3.15 (80.0)	3.63 (92.2)
11	11	9.05 (229.9)	8.03 (204.0)	4.69 (119.1)	3.35 (85.1)	3.63 (92.2)
12 or 13	6	8.75 (222.3)	7.73 (196.3)	4.82 (122.4)	2.90 (73.7)	3.76 (95.5)
12 or 13	7, 8 or 9	8.99 (228.3)	7.97 (202.4)	4.82 (122.4)	3.5 (88.9)	3.76 (95.5)
12 or 13	11	9.19 (233.4)	8.17 (207.5)	4.82 (122.4)	3.35 (85.1)	3.76 (95.5)



## VTM42 Series

### Features

Balanced vane type pumps are excellent for medium- to low-pressure mobile and industrial applications. Available with integrated flow control valves to simplify system design and installation, these pumps are commonly used as pilot and auxiliary pumps for complex systems, and on heavy-duty trucks and interstate buses. Compact size and ease of service allow maximum equipment design flexibility.

- Compact Power Source for Steering Applications
- Integral Relief and Flow Control
- High Efficiency
- Engineered for Extended Life
- Pressure-balanced

### Specifications

PUMP	FLOW IN GPM @ 1200 RPM & 100 PSI (LPM)	DISPL. IN <sup>3</sup> /R (CM <sup>3</sup> /R)	MAX. SPEED (RPM) @ 100 PSI (7 BAR)	MAX. SPEED (RPM) @ 1500 PSI (103 BAR)	MAX. SPEED (RPM) @ 2000 PSI (138 BAR)	MAX. PRESSURE PSI (BAR)	WEIGHT LBS (KGS)
VTM42	1 (3.8)	0.21 (3.44)	7000	5000	4250	2000 (137.9)	14 (6.35)
	1.5 (5.7)	0.31 (5.08)	7000	4500	4000	2000 (137.9)	
	2 (7.6)	0.38 (6.23)	7000	4200	3800	2000 (137.9)	
	4 (15.1)	0.79 (12.95)	7000	2800	2800	2000 (137.9)	
	5 (18.9)	0.96 (15.73)	6000	2600	2300	2000 (137.9)	
	6 (22.7)	1.18 (19.34)	5000	2500	2000	2000 (137.9)	

Values based on using anti-wear type petroleum oil 150 SUS at 100° F (ISO rating of 32 cSt at 38° C) and 0 psi inlet pressure.

# VTM42 Series - Power Steering Pump

## Model Code Breakdown

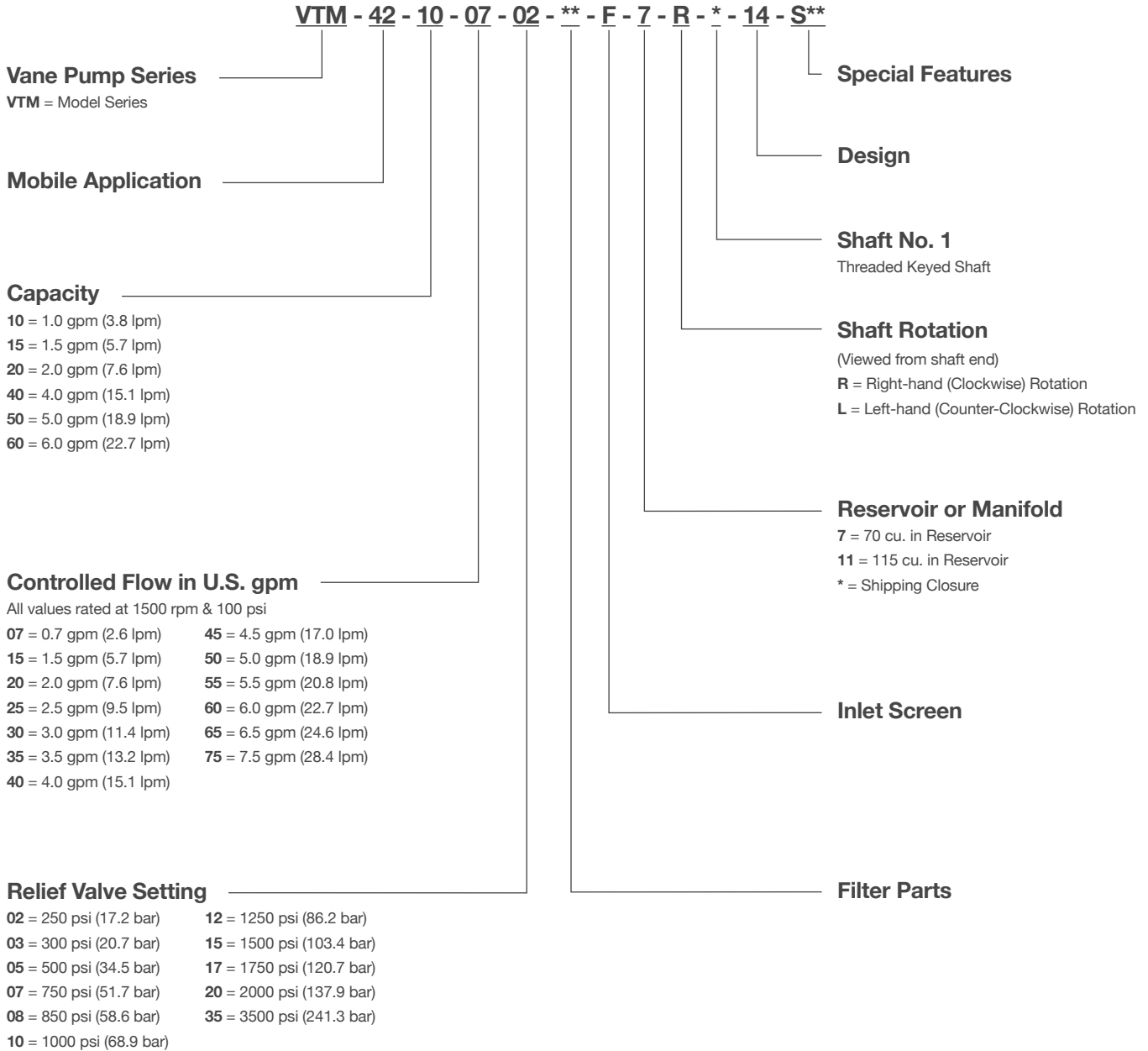

# VTM42 Series - Power Steering Pump

## Parts Breakdown

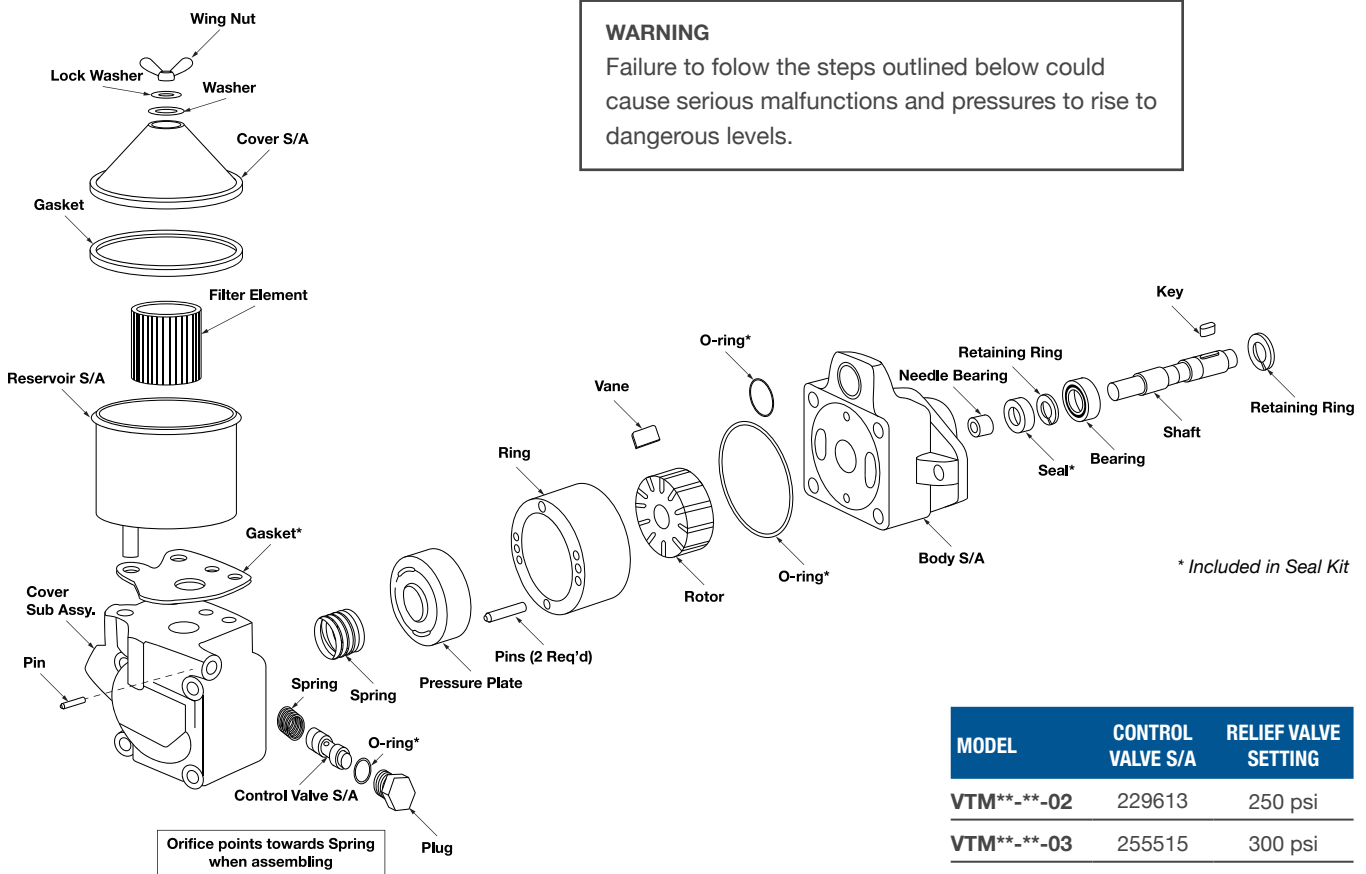

MODEL	CONTROL VALVE S/A	RELIEF VALVE SETTING
VTM**-**-02	229613	250 psi
VTM**-**-03	255515	300 psi
VTM**-**-05	233018	500 psi
VTM**-**-06	247615	600 psi
VTM**-**-07	232794	750 psi
VTM**-**-08	397339	850 psi
VTM**-**-10	232795	1000 psi
VTM**-**-12	232796	1250 psi
VTM**-**-15	232797	1500 psi
VTM**-**-17	232798	1750 psi
VTM**-**-20	232799	2000 psi

MODEL	CARTRIDGE	ROTOR	VANE KIT (10 VANVES)	RING	PIN	PRES. PLATE	SPRING
VTM**-10	923087			296594			
VTM**-15	923088			296595			
VTM**-20	923089	213860	912139	296596	217308		289281
VTM**-40	923090			296597		276396	
VTM**-50	923091			296598			
VTM**-60	923092	213859	922594	296599	154364		245507

PUMP	RESERVOIR S/A KIT	SEAL KIT	BODY S/A KIT	NEEDLE BEARING	SHAFT SEAL	RETAINING RING	BALL BEARING	#1 SHAFT	KEY	RETAINING RING	FILTER ELEMENT
VTM-42	70 cu. in. 923837	922904	923951	222440	263585	193732	148423	250455	1606	172376	213984
	115 cu. in. 923838										

### Changing Cartridge Rotation

To change the cartridge kit rotation slide cam ring over rotor and vanes, making sure all the radius edges of vanes is toward cam ring. Insert locating pins through cam ring, position cam ring so that the arrow on cam ring is pointing in the proper direction.

### Flow Control Relief Valve

When installing the control relief valve, install hex head first into the cover bore seating on the spring. Press plug fully in and insert lock pin.

# VTM42 Series - Power Steering Pump

## Dimensions

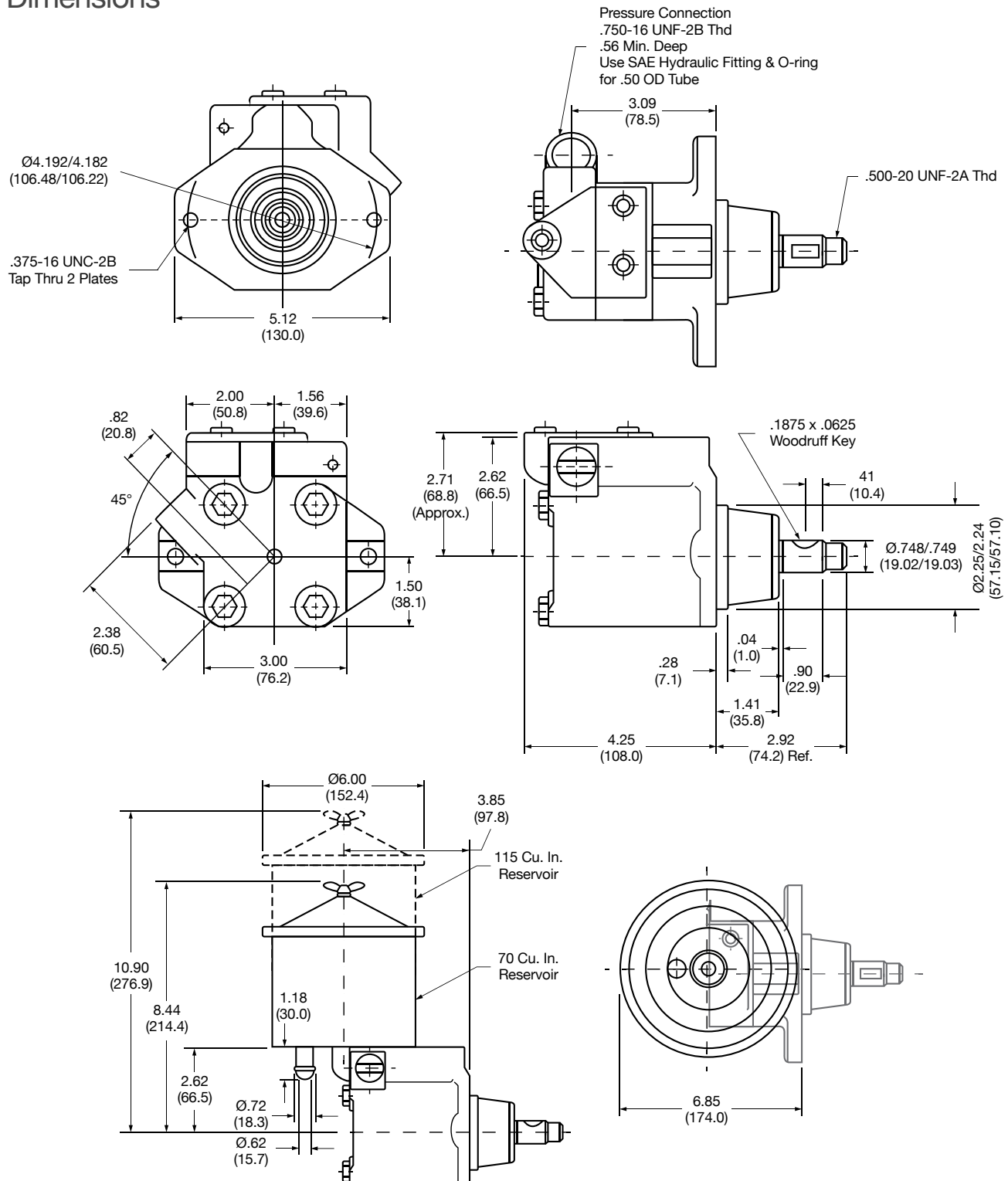

# V Series - Single Pump

## Features

Intravane design pumps provide longer life and increased productivity. Not to mention, they provide application versatility. These units are also known for extremely low sound levels, making them perfect for industrial applications. Compact size and ease of service allow maximum equipment design flexibility. Pumps are available in single, double and thru-drive configurations.

- High Volumetric Efficiency
- Maximum 3000 psi Operating Pressure
- Twelve Vane Design for Quiet Operation
- Hydraulically Balanced for Extended Life
- Versatile
- Compact



## Specifications

PUMP	FLOW IN GPM @ 1200 RPM & 100 PSI (LPM)	DISPL. IN <sup>3</sup> /R (CM <sup>3</sup> /R)	MAX. SPEED (RPM)	MAX. PRESSURE PSI (BAR)	TYP. DELIVERY GPM @ MAX. SPEED & PRESSURE (LPM)	TYPICAL INPUT POWER (HP) @ MAX. SPEED & PRESSURE (KW)	WEIGHT LBS (KG)
20V	5 (18.9)	1.10 (18.0)	1800	3000 (207)	7.5 (28.4)	15.00 (11.2)	26 (11.8)
	8 (30.3)	1.67 (27.4)	1800	3000 (207)	12 (45.4)	22.78 (17.0)	
	11 (41.6)	2.22 (36.4)	1800	3000 (207)	15 (56.8)	30.28 (22.6)	
	12 (45.4)	2.47 (40.5)	1800	3000 (207)	16.4 (62.1)	33.69 (25.1)	
	14 (53.0)	2.78 (45.6)	1800	3000 (207)	18.4 (69.7)	37.91 (28.3)	
25V	12 (45.4)	2.47 (40.5)	1800	2500 (172)	16.4 (62.1)	30.75 (22.9)	32 (14.5)
	14 (53.0)	2.78 (45.6)	1800	2500 (172)	18.4 (69.7)	34.50 (25.7)	
	17 (64.4)	3.39 (55.6)	1800	2500 (172)	22.8 (86.3)	40.00 (29.8)	
	21 (79.5)	4.13 (67.7)	1800	2500 (172)	28 (106.0)	45.60 (34.0)	
35V	21 (79.5)	4.13 (67.7)	1800	2500 (172)	28 (106.0)	45.60 (34.0)	50 (22.7)
	25 (94.6)	4.94 (81.0)	1800	2500 (172)	33 (125.0)	61.00 (45.5)	
	30 (113.6)	5.91 (96.8)	1800	2500 (172)	40.8 (154.4)	73.00 (54.4)	
	35 (132.5)	6.83 (111.9)	1800	2500 (172)	48 (181.7)	82.40 (61.4)	
	38 (143.8)	7.37 (120.8)	1800	2500 (172)	51.2 (193.8)	88.30 (65.8)	
45V	42 (159.0)	8.41 (137.8)	1800	2500 (172)	55 (208.2)	101.00 (75.3)	75 (34)
	50 (189.3)	9.85 (161.4)	1800	2500 (172)	67 (263.6)	117.00 (87.2)	
	60 (227.1)	11.75 (192.5)	1800	2500 (172)	82 (310.4)	139.00 (103.7)	

Values based on using anti-wear type petroleum oil 150 SUS at 100° F (ISO rating of 32 cSt at 38° C) and 0 psi inlet pressure.

# VQ Series - Single Pump

## Features

Intravane design pumps provide longer life and increased productivity. Not to mention, they provide application versatility. These units are also known for extremely low sound levels, making them perfect for mobile applications. Compact size and ease of service allow maximum equipment design flexibility. Pumps are available in single, double and thru-drive configurations.

- High Volumetric Efficiency
- Maximum 3000 psi Operating Pressure
- High Operating Speeds
- Pressure Balanced Brass Flex Plates
- Versatile and Compact
- Contaminant Tolerant



## Specifications

PUMP	FLOW IN GPM @ 1200 RPM & 100 PSI (LPM)	DISPL. IN <sup>3</sup> /R (CM <sup>3</sup> /R)	MAX. SPEED (RPM)	MAX. PRESSURE PSI (BAR)	TYP. DELIVERY GPM @ MAX. SPEED & PRESSURE (LPM)	TYPICAL INPUT POWER (HP) @ MAX. SPEED & PRESSURE (KW)	WEIGHT LBS (KG)
20VQ	5 (18.9)	1.10 (18.0)	2700	3000 (207)	11.0 (41.6)	24.0 (17.9)	26 (11.8)
	8 (30.3)	1.67 (27.4)	2700	3000 (207)	17.0 (64.4)	35.0 (26.1)	
	11 (41.6)	2.22 (36.4)	2700	3000 (207)	23.0 (87.1)	47.5 (35.4)	
	12 (45.4)	2.41 (39.5)	2700	2300 (159)	22.5 (85.2)	38.0 (28.3)	
	14 (53.0)	2.80 (45.9)	2700	2000 (138)	30.0 (113.6)	39.0 (29.1)	
25VQ	12 (45.4)	2.45 (40.1)	2700	3000 (207)	23.0 (87.1)	55.0 (41.0)	32 (14.5)
	14 (53.0)	2.77 (45.4)	2700	3000 (207)	27.0 (102.2)	62.5 (46.6)	
	17 (64.4)	3.39 (55.6)	2500	3000 (207)	31.0 (117.3)	69.5 (51.8)	
	19 (71.9)	3.72 (61.0)	2500	3000 (207)	35.0 (132.5)	76.0 (56.7)	
	21 (79.5)	4.12 (67.5)	2500	3000 (207)	38.0 (143.8)	83.0 (61.9)	
35VQ	21 (79.5)	4.12 (67.5)	2500	3000 (207)	38.0 (143.8)	83.0 (61.9)	50 (22.7)
	25 (94.6)	4.98 (81.6)	2500	3000 (207)	45.0 (170.3)	101.0 (75.3)	
	30 (113.6)	5.96 (97.7)	2500	3000 (207)	55.0 (208.2)	117.5 (87.6)	
	35 (132.5)	6.88 (112.7)	2400	3000 (207)	60.0 (227.1)	132.0 (98.4)	
	38 (143.8)	7.42 (121.6)	2400	3000 (207)	65.0 (246.1)	140.0 (104.4)	
45VQ	42 (159.0)	8.46 (138.6)	2200	2500 (172)	66.5 (251.7)	122.5 (91.3)	75 (34.0)
	45 (170.3)	8.95 (146.7)	2200	2500 (172)	71.0 (268.8)	131.0 (97.7)	
	50 (189.3)	9.90 (162.2)	2200	2500 (172)	79.0 (299.0)	141.0 (105.1)	
	60 (227.1)	11.80 (193.4)	2200	2500 (172)	96.0 (363.4)	170.0 (126.8)	

Values based on using anti-wear type petroleum oil 150 SUS at 100° F (ISO rating of 32 cSt at 38° C) and 0 psi inlet pressure.

# V/VQ Series - Single Pump

## Model Code Breakdown

**35 - V - 38 - A - (S) - 11 - C - 22 - R**

**Model**

20  
25  
35  
45

**Series**

V = Industrial Series  
VQ = Mobile Series

**Ring Capacity in U.S. gpm**

Rated capacity at 1200 rpm & 100 psi

Frame Size	Code (US gpm)	cm <sup>3</sup> /r	in <sup>3</sup> /r
20V/VQ	2	7	0.43
	5	18	1.10
	8	27	1.67
	9	30	1.85
	11	36	2.22
	12	40	2.47
	14	45	2.78
25V/VQ	12	39	2.47
	14	45	2.78
	17	55	3.39
	19	61	3.72
	21	67	4.13
35V/VQ	25	81	4.94
	30	97	5.91
	35	112	6.83
	38	121	7.37
45V/VQ	42	138	8.41
	45	147	8.95
	50	162	9.85
	60	193	11.75

**Shaft Rotation**

R = Omit for Right-hand (Clockwise) Rotation  
L = Left-hand (Counter-Clockwise) Rotation

**Design**

**Outlet Position**  
(Viewed from cover end of pump)

A = Outlet opposite of inlet  
B = Outlet 90° CCW from inlet  
C = Outlet inline with inlet  
D = Outlet 90° CW from inlet

**Shaft**

1 = Straight Keyed  
11 = Splined  
86 = Keyed (Heavy-Duty)  
151 = Splined (For 20V/VQ only)  
(Other Shafts Available)

**Mounting & Shaft Seal Assembly**

S = Flange mount and double shaft seal  
Omit for flange mount with single shaft seal

**Port Connections**

A = SAE 4-Bolt Flange

# V Series - Industrial Single Pump

## Parts Breakdown

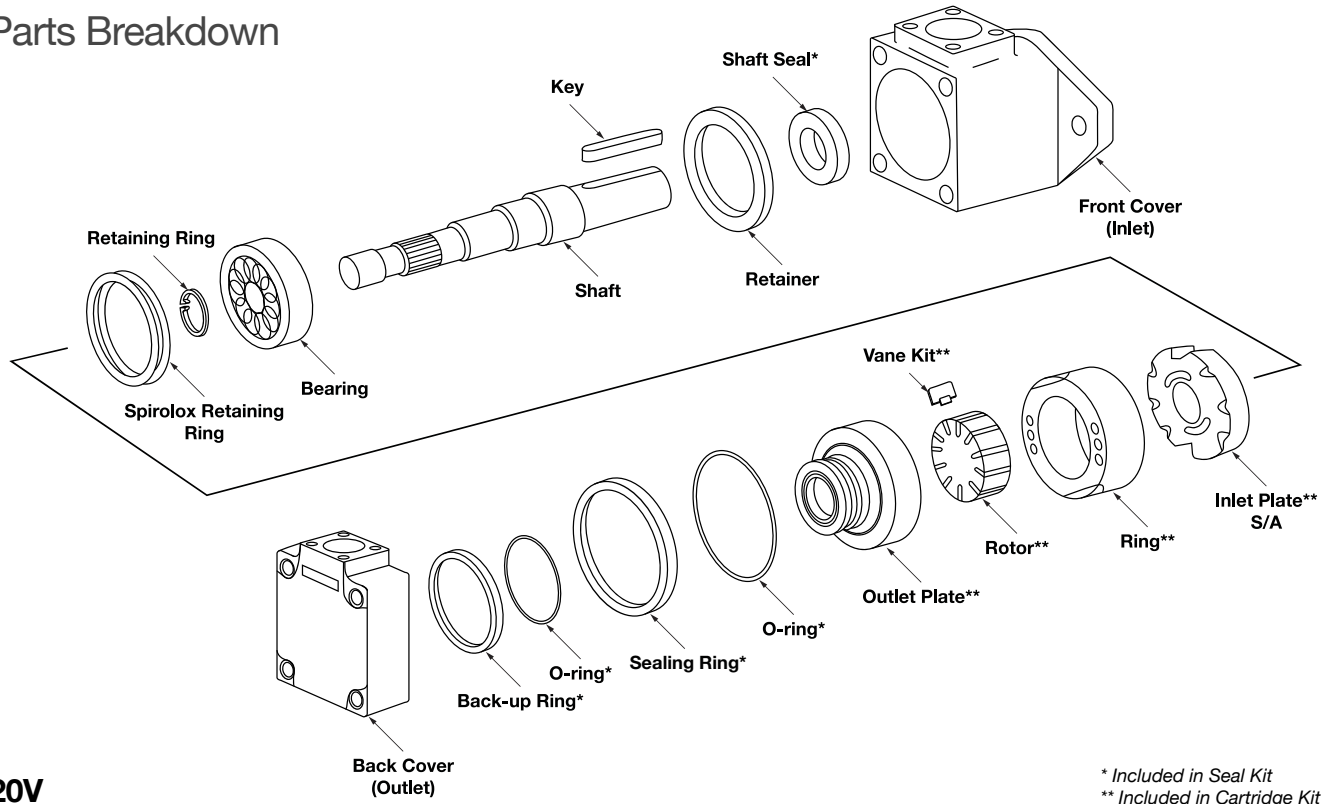

**20V**

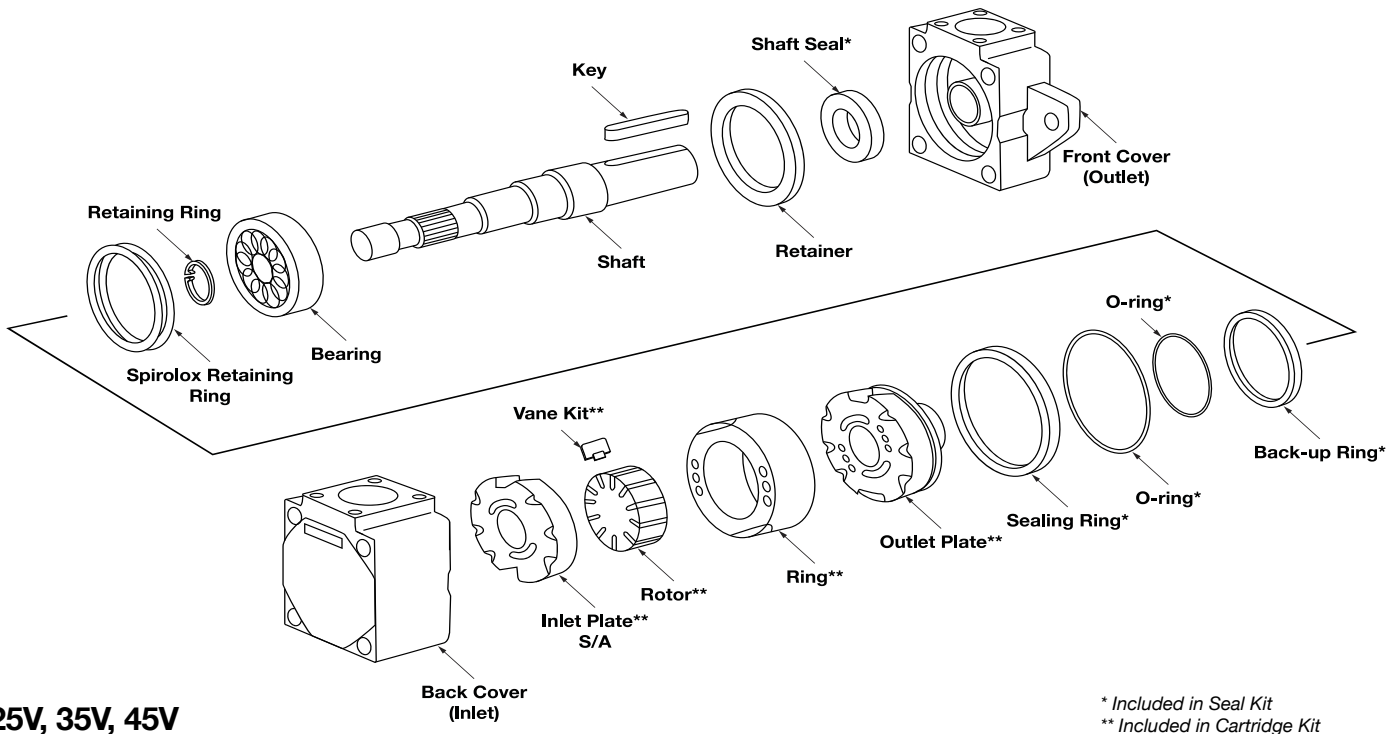

**25V, 35V, 45V**



# V Series - Industrial Single Pump

## Parts Breakdown Listing

PUMP	CARTRIDGE KITS		ROTOR	VANE KIT	RING	INLET PLATE	OUTLET PLATE	SHAFTS	
20V	5	02-102518	402690	02-136720	333624	584383			
	8	02-102519			333625				
	11	02-102520			333626		585382	1	497109
	12	02-102521	403539	02-136721	353901	584384		151	497113
	14	02-102522			353902				
25V	12	02-102532			326984				
	14	02-102533	584618	941214	326985	591016	588690	1	238755
	17	02-102534			326986			11	238929
	21	02-102535			326988			86	419882
35V	21	02-102551			394961				
	25	02-102552			319396				
	30	02-102553	575478	941019	319397	576265	575479	1	233624
	35	02-102554			319398			11	242287
	38	02-102555			319399			86	392669
45V	42	02-102572			297510			1	233369
	50	02-102574	578900	941049	297502	578903	580921	11	242885
	60	02-102575			297503			86	361760

PUMP	BUNA SEAL KIT	VITON SEAL KIT	BUNA SHAFT SEAL	VITON SHAFT SEAL	SECONDARY SHAFT SEAL	BEARING	FRONT COVER	BACK COVER
20V	497125	981322	394976	429286	429283	1704	02-102335	250824
25V	922850	919656	394976	429286	429283	1705	942353	224309
35V	922851	919262	394973	429284	429281	38441	942355	234248
45V	919850	919632	394974	429285	429282	131812	942356	229633

## Bolt Torques

PUMP	COVER BOLT - FT. LB.	CARTRIDGE KIT - IN. LB.
20V	50 (67.8 Nm)	30 (3.4 Nm)
25V	50 (67.8 Nm)	40 (4.5 Nm)
35V	100 (135.6 Nm)	90 (10.2 Nm)
45V	100 (135.6 Nm)	100 (11.3 Nm)

## Filtration

For satisfactory service life, use full flow filtration to provide fluid which meets ISO cleanliness code 19/17 or better.

## Changing Cartridge Rotation

To change Cartridge Kit rotation, reverse the location of the inlet and the outlet support plates. Hand tighten the cartridge screws and use pump cover to align all the parts. Remove the cover and tighten the cartridge screws to the designated value. Sharp edge of vanes must lead in direction of rotation.

# VQ Series - Mobile Single Pump

## Parts Breakdown

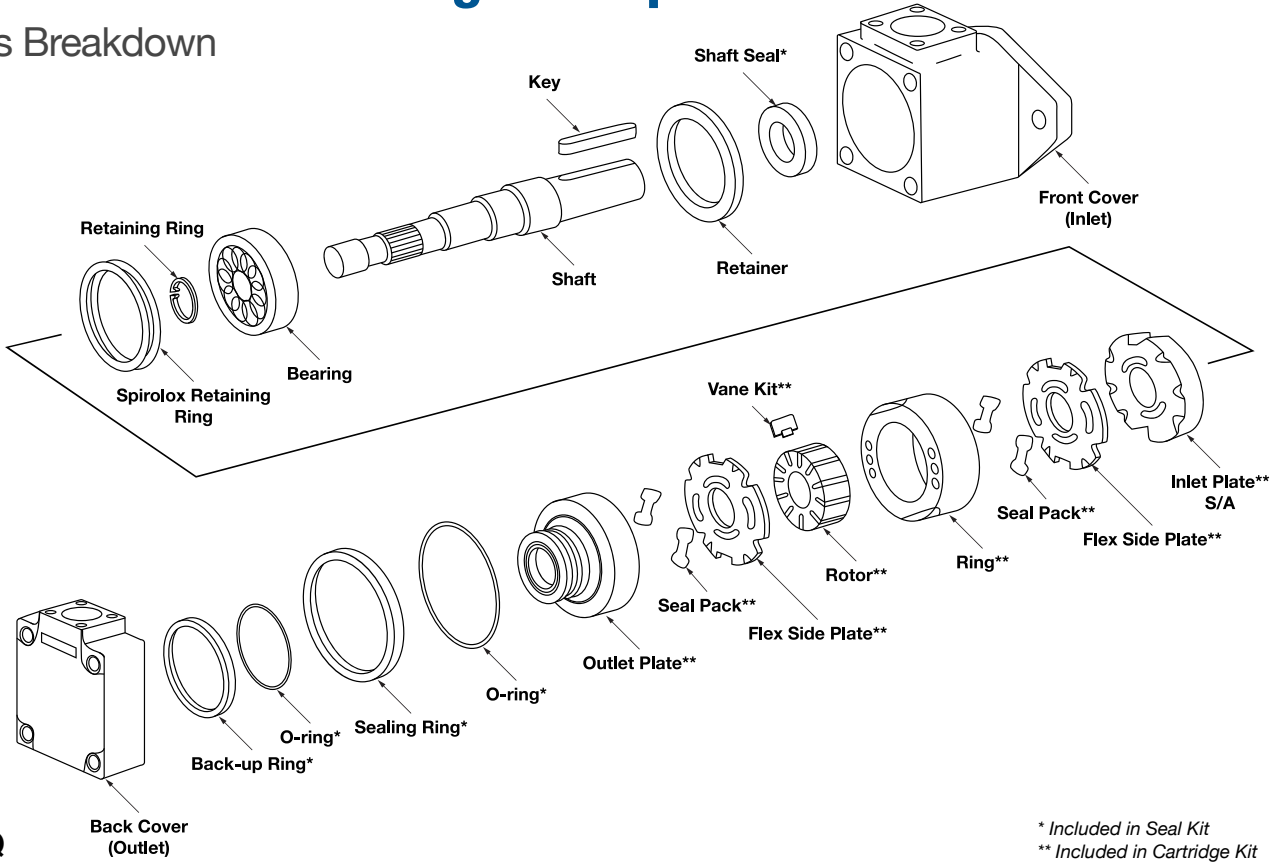

## 25VQ, 35VQ, 45VQ

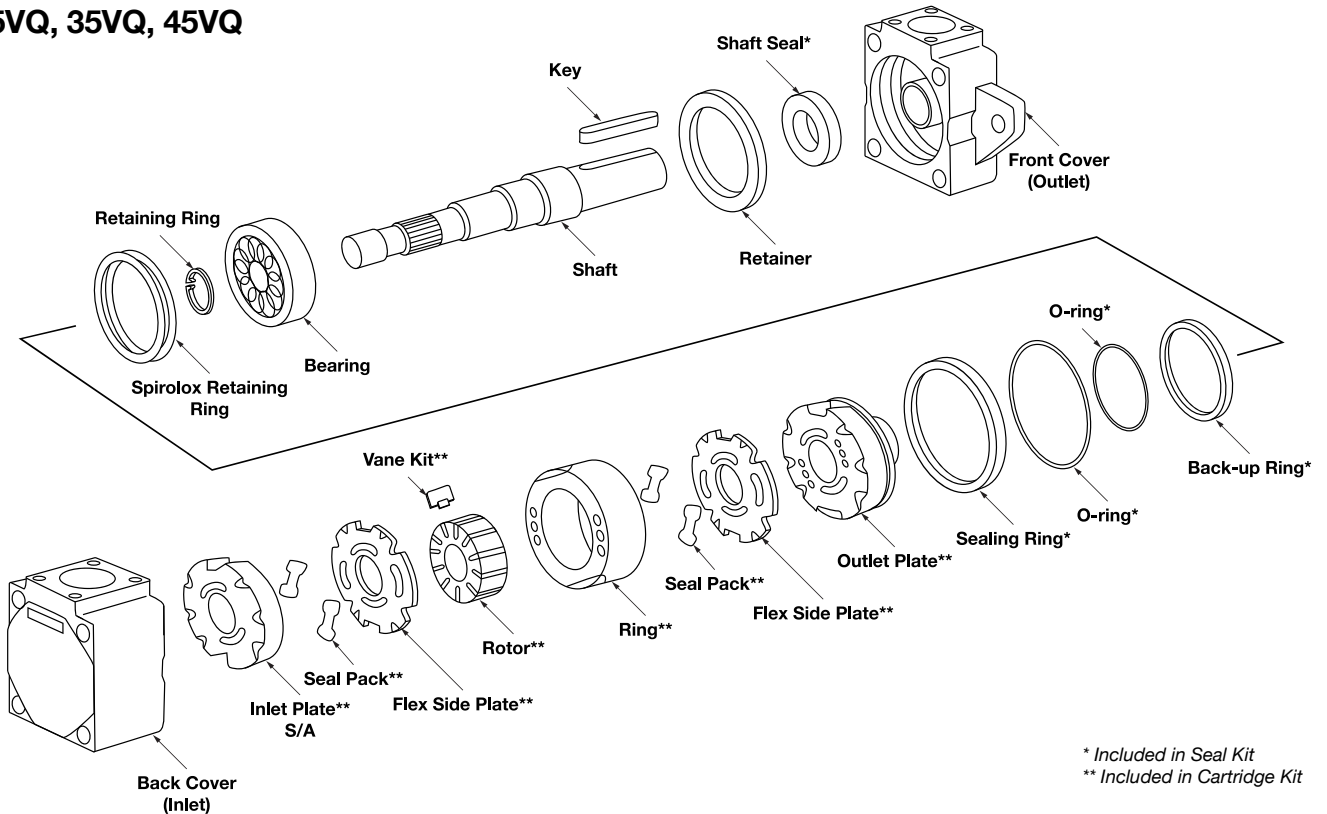

# VQ Series - Mobile Single Pump

## Parts Breakdown Listing

PUMP	CARTRIDGE KITS	ROTOR	VANE KIT	RING	FLEX PLATE	INLET PLATE	OUTLET PLATE	SHAFTS
20VQ	5 497115	402690	922741	333624	416423	419502	497502	1 497109 151 497113
	8 497118			333625				
	11 497120	403539	922743	333626	419501			
	12 497121			353901				
	14 497122			353902				
25VQ	12 416439	270597	922710	326984	923956	430805	419079	1 238755
	14 416440			326985				3 242747
	17 416441			326986				11 238929
	21 416442			326988				25 270187
				127 424457				
35VQ	21 413420	262154	922700	394961	923953	430806	412003	1 233624
	25 413421			319396				11 242287
	30 413422			319397				19 275270
	35 413418			319398				
	38 413419			319399				
45VQ	42 416435	283271	922701	297510	923954	430807	415382	1 233369
	50 416436			297502				11 242885
	60 416437			297503				19 265575

PUMP	BUNA SEAL KIT	VITON SEAL KIT	BUNA SHAFT SEAL	VITON SHAFT SEAL	SECONDARY SHAFT SEAL	BEARING	FRONT COVER	BACK COVER
20VQ	497123	451471	394976	429286	429283	1704	02-102335	250824
25VQ	920021	920023	394976	429286	429283	1705	942353	224309
35VQ	920015	920029	394973	429284	429281	38441	942355	234248
45VQ	920025	920027	394974	429282	429285	131812	942356	229633

## Bolt Torques

PUMP	COVER BOLT - FT. LB.	CARTRIDGE KIT - IN. LB.
20VQ	50 (67.8 Nm)	30 (3.4 Nm)
25VQ	50 (67.8 Nm)	45 (5.1 Nm)
35VQ	100 (135.6 Nm)	100 (11.3 Nm)
45VQ	100 (135.6 Nm)	105 (11.9 Nm)

## Filtration

For satisfactory service life, use full flow filtration to provide fluid which meets ISO cleanliness code 19/17 or better.

## Changing Cartridge Rotation

To change Cartridge Kit rotation, reverse the location of the inlet and the outlet support plates. Hand tighten the cartridge screws and use pump cover to align all the parts. Remove the cover and tighten the cartridge screws to the designated value. Sharp edge of vanes must lead in direction of rotation.

# V/VQ Series - Single Pump

## Dimensions

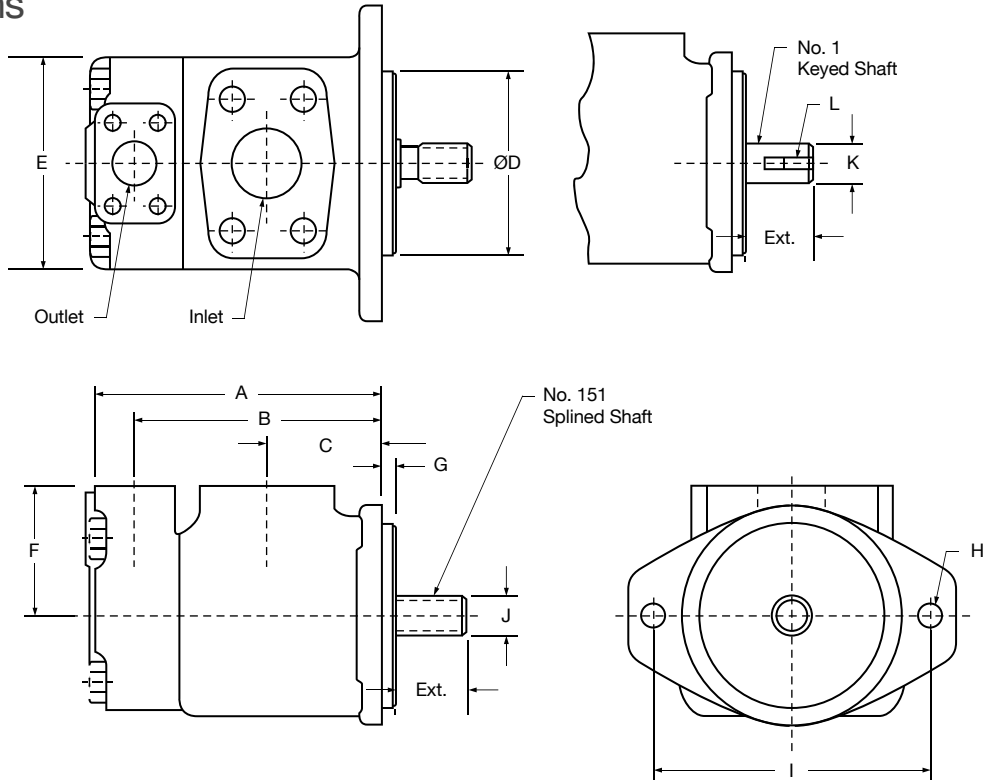

**20V/20VQ**

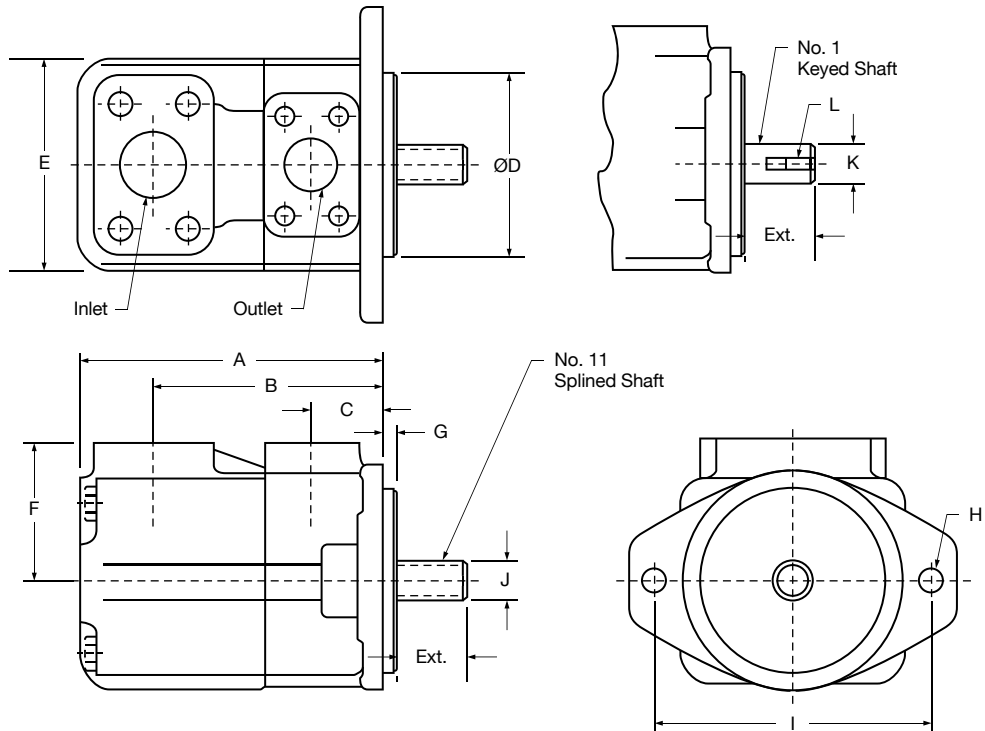

**25V/25VQ, 35V/35VQ, 45V/45VQ**

## V/VQ Series - Single Pump

### Dimensions Chart

	20 SERIES	25 SERIES	30 SERIES	35 SERIES	45 SERIES
<b>A</b>	6.12 (155.4)	6.38 (162.1)	6.96 (176.8)	7.28 (185.0)	8.50 (215.9)
<b>B</b>	5.22 (132.6)	4.75 (120.7)	4.85 (123.2)	4.94 (125.4)	6.02 (153.0)
<b>C</b>	2.50 (63.5)	1.50 (38.1)	1.50 (38.1)	1.50 (38.1)	1.69 (43.0)
<b>D</b>	4" Ø SAE 'B'	4" Ø SAE 'B'	4" Ø SAE 'B'	5" Ø SAE 'C'	5" Ø SAE 'C'
<b>E</b>	4.00 (101.6)	4.62 (117.3)	4.62 (117.3)	5.51 (140.0)	6.36 (161.5)
<b>F</b>	3.00 (76.2)	3.00 (76.2)	3.00 (76.2)	3.25 (82.6)	3.69 (93.7)
<b>G</b>	.375 (9.5)	.375 (9.5)	.375 (9.5)	.375 (9.5)	.500 (12.7)
<b>H</b>	.56 (14.2)	.56 (14.2)	.56 (14.2)	.688 (17.5)	.688 (17.5)
<b>I</b>	5.75 (146.1)	5.75 (146.1)	5.75 (146.1)	7.125 (181.0)	7.125 (181.0)
<b>J</b>	.875 Ø 13t 1.75 Ext.	.875 Ø 13t 1.75 Ext.	.875 Ø 13t 1.75 Ext.	1.25 Ø 14t 2.31 Ext.	1.25 Ø 14t 2.44 Ext.
<b>K</b>	.875 Ø 13t 2.13 Ext.	.875 Ø 13t 2.31 Ext.	.875 Ø 13t 2.31 Ext.	1.25 Ø 14t 2.88 Ext.	1.25 Ø 14t 2.44 Ext.
<b>L</b>	Key .187	Key .187	Key .187	Key .3125	Key .3125
<b>Inlet</b>	1-1/2" FL	1-1/2" FL	1-1/2" FL	2" FL	3" FL
<b>Outlet</b>	3/4" FL	1" FL	1-1/4" FL	1-1/4" FL	1-1/2" FL
<b>Weight</b>	32 lbs (14.5 kg)	32 lbs (14.5 kg)	36 lbs (16.3 kg)	50 lbs (22.7 kg)	75 lbs (34.0 kg)

Dimensions are in inches (millimeters).

### Shaft Descriptions & Codes

PUMP STYLE	CODE	DESCRIPTION	MAJOR DIAM.	EXT.
20V/20VQ	1	3/16 Square Keyed	0.875 (22.2)	2.310 (58.7)
	151	13T 16/32 Splined	0.875 (22.2)	1.750 (44.5)
25V/25VQ	1	13/16 Square Keyed	0.875 (22.2)	2.312 (58.7)
	3	#15 Woodruff Keu	0.875 (22.2)	2.440 (62.0)
30V/30VQ	11	13T 16/32 Splined	0.875 (22.2)	1.750 (44.5)
	25	14T 12/24 Splined	1.250 (31.8)	1.750 (44.5)
	127	14T 12/24 Splined	1.250 (31.8)	2.310 (58.7)
35V/35VQ	1	5/16 Square Keyed	1.250 (31.8)	2.880 (73.2)
	11	14T 12/24 Splined	1.250 (31.8)	2.310 (58.7)
	19	14T 12/24 Extra Long Splined	1.250 (31.8)	3.050 (77.5)
	86	5/16 Heavy-Duty Square Keyed	1.375 (34.9)	3.380 (85.9)
45V/45VQ	1	5/16 Square Keyed	1.250 (31.8)	2.440 (62.0)
	11	14T 12/24 Splined	1.248 (31.7)	2.440 (62.0)
	19	14T 12/24 Extra Long Splined	1.248 (31.7)	3.060 (77.7)
	86	3/8 Heavy-Duty Square Keyed	1.500 (38.1)	3.440 (87.4)

# V Series - Industrial Double Pump

## Features & Specifications

Intravane design pumps provide longer life and increased productivity. Not to mention, they provide application versatility. These units are also known for extremely low sound levels, making them perfect for industrial applications. Compact size and ease of service allow maximum equipment design flexibility. Pumps are available in single, double and thru-drive configurations.

- High Volumetric Efficiency
- Maximum 3000 psi Operating Pressure
- Twelve Vane Design for Quiet Operation
- Hydraulically Balanced for Extended Life
- Versatile & Compact



PUMP	SHAFT END FLOW IN GPM @ 1200 RPM & 100 PSI (LPM)	DISPL. IN <sup>3</sup> /R (CM <sup>3</sup> /R)	MAX. SPEED (RPM)	MAX. PRESS. PSI (BAR)	TYP. DELIVERY GPM @ MAX. SPEED & PRESSURE (LPM)	TYPICAL INPUT POWER (HP) @ MAX. SPEED & PRESSURE (KW)	COVER END FLOW IN GPM @ 1200 RPM & 100 PSI (LPM)	DISPL. IN <sup>3</sup> /R (CM <sup>3</sup> /R)	MAX. SPEED (RPM)	MAX. PRESS. PSI (BAR)	TYP. DELIVERY GPM @ MAX. SPEED & PRESSURE (LPM)	TYPICAL INPUT POWER (HP) @ MAX. SPEED & PRESSURE (KW)
2520V	12 (45.4)	2.47 (40.5)	1800	2500 (172)	16.4 (62.1)	30.75 (22.9)	5 (18.9)	1.10 (18.0)	1800	3000 (207)	7.2 (27.3)	17.00 (12.7)
	14 (53.0)	2.78 (45.6)	1800	2500 (172)	18.4 (69.7)	34.50 (25.7)	8 (30.3)	1.67 (27.4)	1800	3000 (207)	11.1 (42.0)	25.00 (18.6)
	17 (64.4)	3.39 (55.6)	1800	2500 (172)	22.8 (86.3)	35.80 (26.7)	11 (41.6)	2.22 (36.4)	1800	3000 (207)	13.1 (49.6)	34.00 (25.4)
	21 (79.5)	4.13 (67.7)	1800	2500 (172)	28.8 (109.0)	31.00 (23.1)	12 (45.4)	2.41 (39.5)	1800	2500 (172)	17.4 (65.9)	29.75 (22.2)
3520V	14 (53.0)	2.78 (45.6)	1800	2000 (138)	18.6 (70.4)	34.50 (25.7)	14 (53.0)	2.78 (45.6)	1800	2000 (138)	18.6 (70.4)	34.50 (25.7)
	21 (79.5)	4.13 (67.7)	1800	2500 (172)	28.8 (109.0)	31.00 (23.1)	5 (18.9)	1.10 (18.0)	1800	3000 (207)	7.2 (27.3)	17.00 (12.7)
	25 (94.6)	4.94 (81.0)	1800	2500 (172)	33.9 (128.3)	61.00 (45.5)	8 (30.3)	1.67 (27.4)	1800	3000 (207)	11.1 (42.0)	25.00 (18.6)
	30 (113.6)	5.91 (96.8)	1800	2500 (172)	40.8 (154.4)	73.00 (54.4)	11 (41.6)	2.22 (36.4)	1800	3000 (207)	13.1 (49.6)	34.00 (25.4)
3525V	35 (132.5)	6.83 (111.9)	1800	2500 (172)	48.0 (181.7)	82.40 (61.4)	12 (45.4)	2.41 (39.5)	1800	2500 (172)	17.4 (65.9)	29.75 (22.2)
	38 (143.8)	7.37 (120.8)	1800	2500 (172)	51.2 (193.8)	88.30 (65.8)	14 (53.0)	2.78 (45.6)	1800	2500 (172)	18.6 (70.4)	34.50 (25.7)
	21 (79.5)	4.13 (67.7)	1800	2500 (172)	28.8 (109.0)	31.00 (23.1)	12 (45.4)	2.41 (39.5)	1800	2500 (172)	16.0 (60.6)	30.75 (22.9)
	25 (94.6)	4.94 (81.0)	1800	2500 (172)	33.9 (128.3)	61.00 (45.5)	14 (53.0)	2.81 (46.0)	1800	2500 (172)	18.6 (70.4)	34.50 (25.7)
4520V	30 (113.6)	5.91 (96.8)	1800	2500 (172)	40.8 (154.4)	73.00 (54.4)	17 (64.4)	3.39 (55.6)	1800	2500 (172)	22.5 (85.2)	35.80 (26.7)
	35 (132.5)	6.83 (111.9)	1800	2500 (172)	48.0 (181.7)	82.40 (61.4)	21 (79.5)	4.13 (67.7)	1800	2500 (172)	27.5 (104.1)	45.60 (34.0)
	42 (159.0)	8.41 (137.8)	1800	2500 (172)	55.0 (208.2)	101.00 (75.3)	5 (18.9)	1.10 (18.0)	1800	3000 (207)	7.2 (27.3)	17.00 (12.7)
	50 (189.2)	9.85 (161.4)	1800	2500 (172)	57.0 (215.8)	110.00 (82.0)	8 (30.3)	1.67 (27.4)	1800	3000 (207)	11.1 (42.0)	25.00 (18.6)
4525V	60 (227.1)	11.75 (192.5)	1800	2500 (172)	67.0 (253.6)	117.00 (87.2)	11 (41.6)	2.22 (36.4)	1800	3000 (207)	13.1 (49.6)	34.00 (25.4)
	12 (45.4)	2.41 (39.5)	1800	2500 (172)	17.4 (65.9)	29.75 (22.2)	12 (45.4)	2.41 (39.5)	1800	2500 (172)	17.4 (65.9)	29.75 (22.2)
	14 (53.0)	2.78 (45.6)	1800	2500 (172)	18.6 (70.4)	34.50 (25.7)	14 (53.0)	2.78 (45.6)	1800	2500 (172)	18.6 (70.4)	34.50 (25.7)
	42 (159.0)	8.41 (137.8)	1800	2500 (172)	55.0 (208.2)	101.00 (75.3)	12 (45.4)	2.41 (39.5)	1800	2500 (172)	16.0 (60.6)	30.75 (22.9)
4535V	50 (189.2)	9.85 (161.4)	1800	2500 (172)	57.0 (215.8)	110.00 (82.0)	14 (53.0)	2.81 (46.0)	1800	2500 (172)	18.6 (70.4)	34.50 (25.7)
	60 (227.1)	11.75 (192.5)	1800	2500 (172)	67.0 (253.6)	117.00 (87.2)	17 (64.4)	3.39 (55.6)	1800	2500 (172)	22.5 (85.2)	35.80 (26.7)
	21 (79.5)	4.13 (67.7)	1800	2500 (172)	27.5 (104.1)	45.60 (34.0)	21 (79.5)	4.13 (67.7)	1800	2500 (172)	27.5 (104.1)	45.60 (34.0)
	42 (159.0)	8.41 (137.8)	1800	2500 (172)	55.0 (208.2)	101.00 (75.3)	21 (79.5)	4.13 (67.7)	1800	2500 (172)	28.8 (109.0)	31.00 (23.1)
4535V	50 (189.2)	9.85 (161.4)	1800	2500 (172)	57.0 (215.8)	110.00 (82.0)	25 (94.6)	4.94 (81.0)	1800	2500 (172)	33.9 (128.3)	61.00 (45.5)
	60 (227.1)	11.75 (192.5)	1800	2500 (172)	67.0 (253.6)	117.00 (87.2)	30 (113.6)	5.91 (96.8)	1800	2500 (172)	40.8 (154.4)	73.00 (54.4)
	35 (132.5)	6.83 (111.9)	1800	2500 (172)	48.0 (181.7)	82.40 (61.4)	38 (143.8)	7.37 (120.8)	1800	2500 (172)	51.2 (193.8)	88.30 (65.8)

Values based on using anti-wear type petroleum oil 150 SUS at 100° F (ISO rating of 32 cSt at 38° C) and 0 psi inlet pressure.

# VQ Series - Mobile Double Pump

## Features & Specifications

Intravane design pumps provide longer life and increased productivity. Not to mention, they provide application versatility. These units are also known for extremely low sound levels, making them perfect for mobile applications. Compact size and ease of service allow maximum equipment design flexibility. Pumps are available in single, double and thru-drive configurations.

- High Volumetric Efficiency
- Maximum 3000 psi Operating Pressure
- High Operating Speeds
- Pressure Balanced Brass Flex Plates
- Contaminant Tolerant



PUMP	SHAFT END FLOW IN GPM @ 1200 RPM & 100 PSI (LPM)	DISPL. IN <sup>3</sup> /R (CM <sup>3</sup> /R)	MAX. SPEED (RPM)	MAX. PRESS. PSI (BAR)	TYP. DELIVERY GPM @ MAX. SPEED & PRESSURE (LPM)	TYPICAL INPUT POWER (HP) @ MAX. SPEED & PRESSURE (KW)	COVER END FLOW IN GPM @ 1200 RPM & 100 PSI (LPM)	DISPL. IN <sup>3</sup> /R (CM <sup>3</sup> /R)	MAX. SPEED (RPM)	MAX. PRESS. PSI (BAR)	TYP. DELIVERY GPM @ MAX. SPEED & PRESSURE (LPM)	TYPICAL INPUT POWER (HP) @ MAX. SPEED & PRESSURE (KW)
2520VQ	12 (45.4)	2.47 (40.5)	2700	3000 (207)	23.0 (87.1)	55.0 (41.0)	5 (18.9)	1.10 (18.0)	2700	3000 (207)	11.0 (41.6)	24.0 (17.9)
	14 (53.0)	2.78 (45.6)	2700	3000 (207)	27.0 (102.2)	62.5 (46.6)	8 (30.3)	1.67 (27.4)	2700	3000 (207)	17.0 (64.4)	35.0 (26.1)
	17 (64.4)	3.39 (55.6)	2700	3000 (207)	31.0 (117.3)	69.5 (51.8)	11 (41.6)	2.22 (36.4)	2700	3000 (207)	23.0 (87.1)	47.5 (35.4)
	21 (79.5)	4.13 (67.7)	2700	3000 (207)	38.0 (143.8)	76.0 (56.7)	12 (45.4)	2.41 (39.5)	2700	2300 (159)	25.5 (96.5)	38.0 (28.3)
3520VQ	14 (53.0)	2.78 (45.6)	2700	2000 (138)	30.0 (113.6)	39.0 (29.1)	14 (53.0)	2.78 (45.6)	2700	2000 (138)	30.0 (113.6)	39.0 (29.1)
	21 (79.5)	4.13 (67.7)	2500	3000 (207)	38.0 (143.8)	83.0 (61.9)	5 (18.9)	1.10 (18.0)	2500	3000 (207)	11.0 (41.6)	24.0 (17.9)
	25 (94.6)	4.94 (81.0)	2500	3000 (207)	45.0 (170.3)	101.0 (75.3)	8 (30.3)	1.67 (27.4)	2500	3000 (207)	17.0 (64.4)	35.0 (26.1)
	30 (113.6)	5.91 (96.8)	2500	3000 (207)	55.0 (208.2)	117.5 (87.6)	11 (41.6)	2.22 (36.4)	2500	3000 (207)	23.0 (87.1)	47.5 (35.4)
3525VQ	35 (132.5)	6.83 (111.9)	2400	3000 (207)	60.0 (227.1)	132.0 (98.4)	12 (45.4)	2.41 (39.5)	2500	2300 (159)	25.5 (96.5)	38.0 (28.3)
	38 (143.8)	7.37 (120.8)	2400	3000 (207)	65.0 (246.1)	140.0 (104.4)	14 (53.0)	2.78 (45.6)	2500	2000 (138)	30.0 (113.6)	39.0 (29.1)
	21 (79.5)	4.13 (67.7)	2500	3000 (207)	38.0 (143.8)	83.0 (61.9)	12 (45.4)	2.41 (39.5)	2500	3000 (207)	21.0 (79.5)	51.0 (38.0)
	25 (94.6)	4.94 (81.0)	2500	3000 (207)	45.0 (170.3)	101.0 (75.3)	14 (53.0)	2.81 (46.0)	2500	3000 (207)	24.0 (90.8)	58.0 (43.3)
4520VQ	35 (132.5)	6.83 (111.9)	2400	3000 (207)	60.0 (227.1)	132.0 (98.4)	17 (64.4)	3.39 (55.6)	2500	3000 (207)	31.0 (117.3)	69.0 (51.5)
	38 (143.8)	7.37 (120.8)	2400	3000 (207)	65.0 (246.1)	140.0 (104.4)	21 (79.5)	4.13 (67.7)	2500	3000 (207)	38.0 (143.8)	83.0 (61.9)
	42 (159.0)	8.41 (137.8)	2200	2500 (172)	66.5 (251.7)	122.5 (91.3)	5 (18.9)	1.10 (18.0)	2200	3000 (207)	11.0 (41.6)	24.0 (17.9)
	50 (189.2)	9.85 (161.4)	2200	2500 (172)	79.0 (299.0)	141.0 (105.1)	8 (30.3)	1.67 (27.4)	2200	3000 (207)	17.0 (64.4)	35.0 (26.1)
4525VQ	60 (227.1)	11.75 (192.5)	2200	2500 (172)	96.0 (363.4)	170.0 (126.8)	11 (41.6)	2.22 (36.4)	2200	3000 (207)	23.0 (87.1)	47.5 (35.4)
	12 (45.4)	2.41 (39.5)	2200	2300 (159)	25.5 (96.5)	38.0 (28.3)	12 (45.4)	2.41 (39.5)	2200	2300 (159)	25.5 (96.5)	38.0 (28.3)
	14 (53.0)	2.78 (45.6)	2200	2000 (138)	30.0 (113.6)	39.0 (29.1)	14 (53.0)	2.78 (45.6)	2200	2000 (138)	30.0 (113.6)	39.0 (29.1)
	42 (159.0)	8.41 (137.8)	2200	2500 (172)	66.5 (251.7)	122.5 (91.3)	12 (45.4)	2.41 (39.5)	2200	3000 (207)	21.0 (79.5)	51.0 (38.0)
4535VQ	50 (189.2)	9.85 (161.4)	2200	2500 (172)	79.0 (299.0)	141.0 (105.1)	14 (53.0)	2.81 (46.0)	2200	3000 (207)	24.0 (90.8)	58.0 (43.3)
	60 (227.1)	11.75 (192.5)	2200	2500 (172)	96.0 (363.4)	170.0 (126.8)	17 (64.4)	3.39 (55.6)	2200	3000 (207)	31.0 (117.3)	69.0 (51.5)
	21 (79.5)	4.13 (67.7)	2200	3000 (207)	38.0 (143.8)	83.0 (61.9)	21 (79.5)	4.13 (67.7)	2200	3000 (207)	38.0 (143.8)	83.0 (61.9)
	42 (159.0)	8.41 (137.8)	2200	2500 (172)	66.5 (251.7)	122.5 (91.3)	21 (79.5)	4.13 (67.7)	2200	3000 (207)	38.0 (143.8)	83.0 (61.9)
4535VQ	50 (189.2)	9.85 (161.4)	2200	2500 (172)	79.0 (299.0)	141.0 (105.1)	25 (94.6)	4.94 (81.0)	2200	3000 (207)	45.0 (170.3)	101.0 (75.3)
	60 (227.1)	11.75 (192.5)	2200	2500 (172)	96.0 (363.4)	170.0 (126.8)	30 (113.6)	5.91 (96.8)	2200	3000 (207)	55.0 (208.2)	117.5 (87.6)
	35 (132.5)	6.83 (111.9)	2200	3000 (207)	60.0 (227.1)	132.0 (98.4)	35 (132.5)	6.83 (111.9)	2200	3000 (207)	60.0 (227.1)	132.0 (98.4)
	38 (143.8)	7.37 (120.8)	2200	3000 (207)	65.0 (246.1)	140.0 (104.4)	38 (143.8)	7.37 (120.8)	2200	3000 (207)	65.0 (246.1)	140.0 (104.4)

Values based on using anti-wear type petroleum oil 150 SUS at 100° F (ISO rating of 32 cSt at 38° C) and 0 psi inlet pressure.

# V/VQ Series - Double Pump

## Model Code Breakdown

2520 - V - 12 - A - 14 - (S) - 1 - CC - 22 - R

### Model

2520	4520
3520	4525
3525	4535

### Series

V = Industrial Series  
VQ = Mobile Series

### Shaft End Ring Capacity in U.S. gpm

Rated capacity at 1200 rpm & 100 psi

Frame Size	Code (US gpm)	cm <sup>3</sup> /r	in <sup>3</sup> /r
25V/VQ	10	33	2.01
	12	39	2.47
	14	45	2.78
	17	55	3.39
35V/VQ	21	67	4.13
	25	81	4.94
	30	97	5.91
	35	112	6.83
45V/VQ	38	121	7.37
	42	138	8.41
	45	147	8.95
	50	162	9.85
	60	193	11.75

### Port Connections

Code	Inlet	Outlet #1 Shaft End	Outlet #2 Cover End	Pump Series
A	4 Bolt Flg.	4 Bolt Flg.	4 Bolt Flg.	All
C	4 Bolt Flg.	SAE St. Thd.	SAE St. Thd.	2520
E	4 Bolt Flg.	4 Bolt Flg.	SAE St. Thd.	All except 4535

### Cover End Ring Capacity in U.S. gpm

Rated capacity at 1200 rpm & 100 psi

Frame Size	Code (US gpm)	cm <sup>3</sup> /r	in <sup>3</sup> /r
**20V/VQ	2	7	0.43
	5	18	1.10
	8	27	1.67
	9	30	1.85
	11	36	2.22
**25V/VQ	12	40	2.47
	14	45	2.78
	10	33	2.01
	12	39	2.47
	14	45	2.78
**35V/VQ	17	55	3.39
	21	67	4.13
	25	81	4.94
	30	97	5.91
	35	112	6.83
	38	121	7.37

### Shaft Rotation

R = Omit for Right-hand (Clockwise) Rotation  
L = Left-hand (Counter-Clockwise) Rotation

### Design

#### Outlet Port Position

(Viewed from cover end of pump)

#### All Series except 4535V/VQ

**With No. 1 Outlet (shaft end) opposite inlet port**

AA = No. 2 Outlet 135° CCW from inlet  
AB = No. 2 Outlet 45° CCW from inlet  
AC = No. 2 Outlet 45° CW from inlet  
AD = No. 2 Outlet 135° CW from inlet

**With No. 1 Outlet (shaft end) 90° CCW from inlet port**

BA = No. 2 Outlet 135° CCW from inlet  
BB = No. 2 Outlet 45° CCW from inlet  
BC = No. 2 Outlet 45° CW from inlet  
BD = No. 2 Outlet 135° CW from inlet

**With No. 1 Outlet (shaft end) inline with inlet port**

CA = No. 2 Outlet 135° CCW from inlet  
CB = No. 2 Outlet 45° CCW from inlet  
CC = No. 2 Outlet 45° CW from inlet  
CD = No. 2 Outlet 135° CW from inlet

**With No. 1 Outlet (shaft end) 90° CW from inlet port**

DA = No. 2 Outlet 135° CCW from inlet  
DB = No. 2 Outlet 45° CCW from inlet  
DC = No. 2 Outlet 45° CW from inlet  
DD = No. 2 Outlet 135° CW from inlet

#### Series 4535V/VQ

**With No. 1 Outlet (shaft end) opposite inlet port**

AA = No. 2 Outlet opposite of inlet  
AB = No. 2 Outlet 90° CCW from inlet  
AC = No. 2 Outlet inline with inlet  
AD = No. 2 Outlet 90° CW from inlet

**With No. 1 Outlet (shaft end) 90° CCW from inlet port**

BA = No. 2 Outlet opposite of inlet  
BB = No. 2 Outlet 90° CCW from inlet  
BC = No. 2 Outlet inline with inlet  
BD = No. 2 Outlet 90° CW from inlet

**With No. 1 Outlet (shaft end) inline with inlet port**

CA = No. 2 Outlet opposite of inlet  
CB = No. 2 Outlet 90° CCW from inlet  
CC = No. 2 Outlet inline with inlet  
CD = No. 2 Outlet 90° CW from inlet

**With No. 1 Outlet (shaft end) 90° CW from inlet port**

DA = No. 2 Outlet opposite of inlet  
DB = No. 2 Outlet 90° CCW from inlet  
DC = No. 2 Outlet inline with inlet  
DD = No. 2 Outlet 90° CW from inlet

### Mounting & Shaft Seal Assembly

S = Flange mount and double shaft seal  
Omit for flange mount with single shaft seal

### Shaft

1 = Straight Keyed  
11 = Splined  
86 = Keyed (Heavy-Duty)  
(Other Shafts Available)



# V Series - Industrial Double Pump

## Parts Breakdown

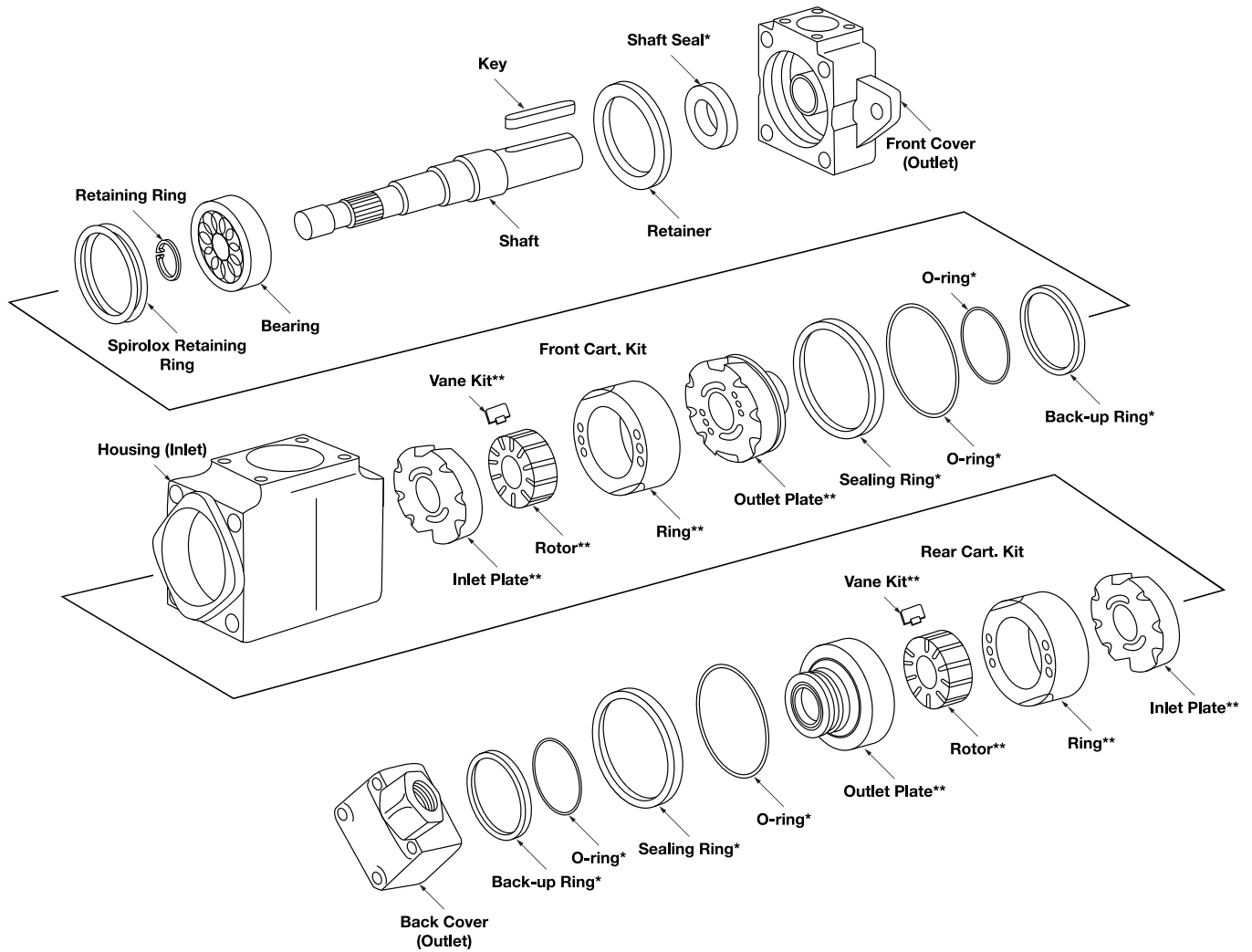

**2520V, 3520V, 4520V,  
3525V, 4525V**

\* Included in Seal Kit  
\*\* Included in Cartridge Kit

# V Series - Industrial Double Pump

## Parts Breakdown

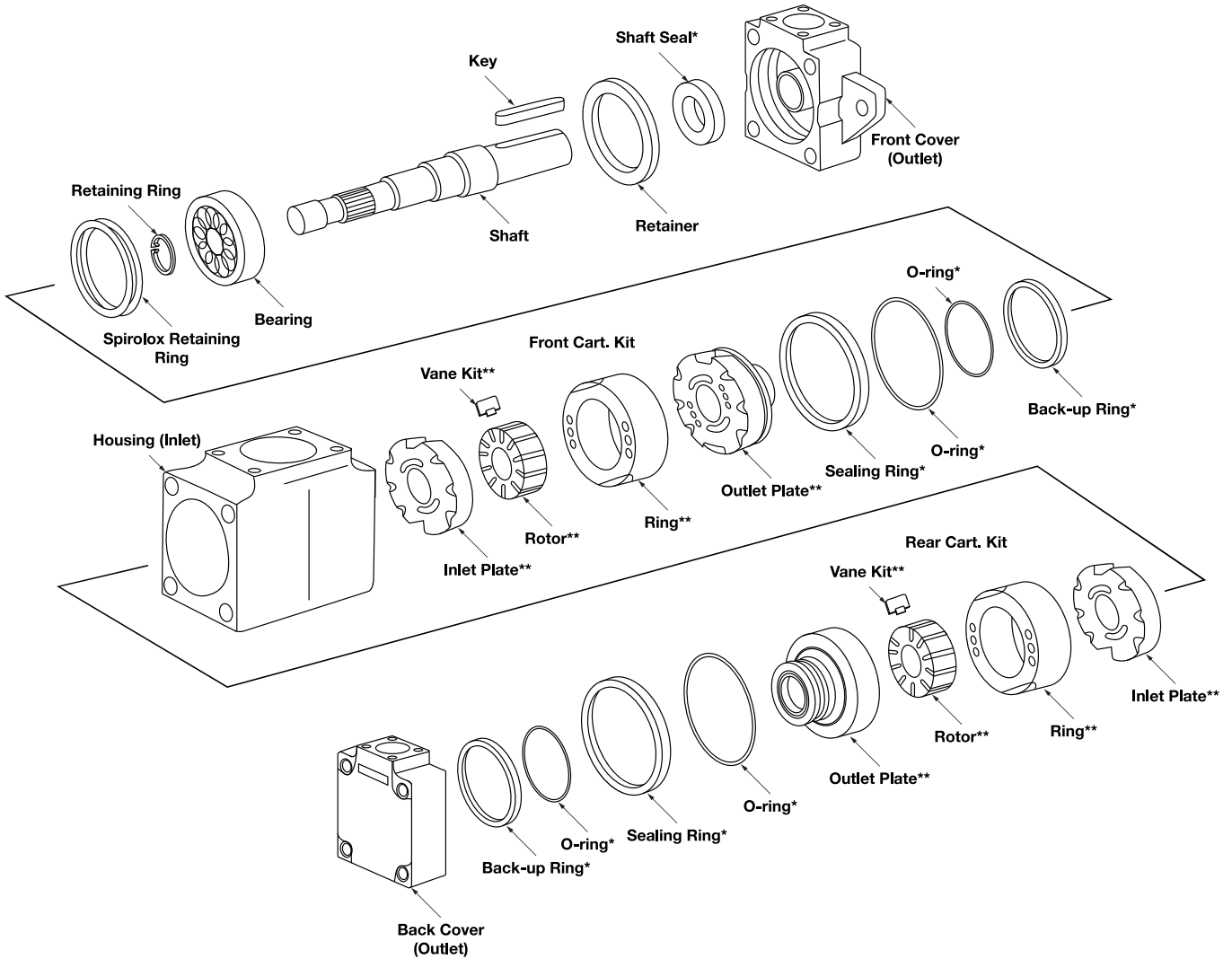

**4535V**

\* Included in Seal Kit  
 \*\* Included in Cartridge Kit

# V Series - Industrial Double Pump

## Parts Breakdown Listing

PUMP	FRONT CART. KIT	ROTOR	VANE KIT	RING	REAR CART. KIT	ROTOR	VANE KIT	RING	SHAFTS
2520V	12 02-102532			326984	2 02-102506			388693	
	14 02-102533			326985	5 02-102507	402690	922741	333624	
	17 02-102534	584618	941214	326986	8 02-102508			333625	1 254964
	21 02-102535			326988	11 02-102509			333626	11 254848
3520V	21 02-102551			394961	12 02-102510	403539	922743	353901	
	25 02-102552			319396	14 02-102511			353902	
	30 02-102553	575478	94019	319397	2 02-102506			388693	
	35 02-102554			319398	5 02-102507	402690	922741	333624	
	38 02-102555			319399	8 02-102508			333625	1 258249
3525V	21 02-102551			394961	11 02-102509			333626	11 258250
	25 02-102552			319396	12 02-102510	403539	922743	353901	86 394517
	30 02-102553	575478	941019	319397	14 02-102511			353902	
	35 02-102554			319398	12 02-102536			326984	
	38 02-102555			319399	14 02-102537	584618	941214	326985	1 243448
4520V	42 02-102572			297510	17 02-102538			326986	11 243449
	50 02-102574	578900	941049	297502	21 02-102539			326988	86 394036
	60 02-102575			297503					
4525V	42 02-102572			297510	2 02-102506			388693	
	50 02-102574	283871	922701	297502	5 02-102507	402690	922741	333624	
	60 02-102575			297503	8 02-102508			333625	1 255533
4535V	42 02-102572			297510	11 02-102509			333626	11 255536
	50 02-102574	283871	922701	297502	12 02-102510	403539	922743	353901	86 361761
	60 02-102575			297503	14 02-102511			353902	
4535V	42 02-102572			297510	12 02-102536			326984	
	50 02-102574	283871	922701	297502	14 02-102537	584618	941214	326985	1 233524
	60 02-102575			297503	17 02-102538			326986	11 233527
					21 02-102539			326988	86 361762
4535V	42 02-102572			297510	25 02-102556			319396	
	50 02-102574	283871	922701	297502	30 02-102557	575478	941019	319397	1 289083
	60 02-102575			297503	35 02-102558			319398	11 289084
					38 02-102559			319399	86 361763

PUMP	BUNA SEAL KIT	VITON SEAL KIT	BUNA SHAFT SEAL	VITON SHAFT SEAL	SECONDARY SHAFT SEAL	BEARING	FRONT COVER	MIDDLE COVER	BACK COVER
2520V	922856	919303	394976	429286	429283	001705	942353	251263	250824
3520V	922859	919304	394973	429284	429281	038441	942355	250818	250824
3525V	922862	919305	394973	429284	429281	038441	942355	230189	231532
4520V	922863	919616	394974	429285	429282	131812	942356	252283	250824
4525V	922865	919345	394974	429285	429282	131812	942356	370071	231532
4535V	922866	919346	394974	429285	429282	131812	942356	270640	270679

# V Series - Industrial Double Pump

## Bolt Torques

PUMP	FRONT HOUSING - FT. LB.	REAR COVER - FT. LB.	FRONT CART. KIT - IN LB.	REAR CART. KIT - IN. LB.
<b>2520V</b>	75 (101.7 Nm)	50 (67.8 Nm)	40 (4.5 Nm)	25 (2.8 Nm)
<b>3520V</b>	150 (203.4 Nm)	50 (67.8 Nm)	90 (10.2 Nm)	25 (2.8 Nm)
<b>3525V</b>	150 (203.4 Nm)	75 (101.7 Nm)	90 (10.2 Nm)	40 (4.5 Nm)
<b>4520V</b>	275 (372.8 Nm)	50 (67.8 Nm)	100 (11.3 Nm)	25 (2.8 Nm)
<b>4525V</b>	275 (372.8 Nm)	75 (101.7 Nm)	100 (11.3 Nm)	20 (2.3 Nm)
<b>4535V</b>	275 (372.8 Nm)	75 (101.7 Nm)	100 (11.3 Nm)	90 (10.2 Nm)

## Changing Cartridge Rotation

To change Cartridge Kit rotation, reverse the location of the inlet and the outlet support plates. Hand tighten the cartridge screws and use pump cover to align all the parts. Remove the cover and tighten the cartridge screws to the designated value. Sharp edge of vanes must lead in direction of rotation.

## Filtration

For satisfactory service life, use full flow filtration to provide fluid which meets ISO cleanliness code 19/17 or better.

# VQ Series - Mobile Double Pump

## Parts Breakdown

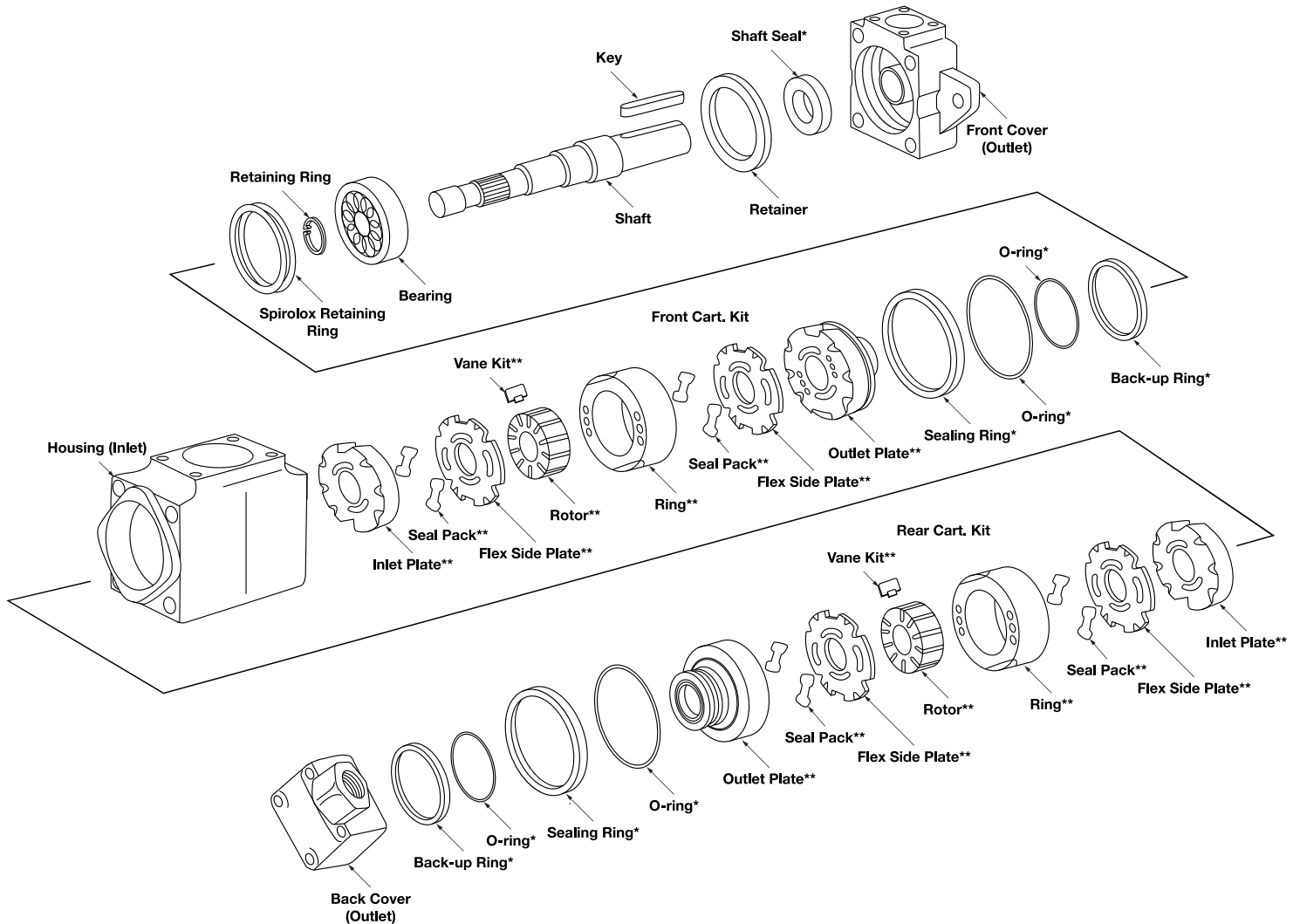

2520VQ, 3520VQ, 4520VQ,  
3525VQ, 4525VQ

\* Included in Seal Kit  
\*\* Included in Cartridge Kit

# VQ Series - Mobile Double Pump

## Parts Breakdown

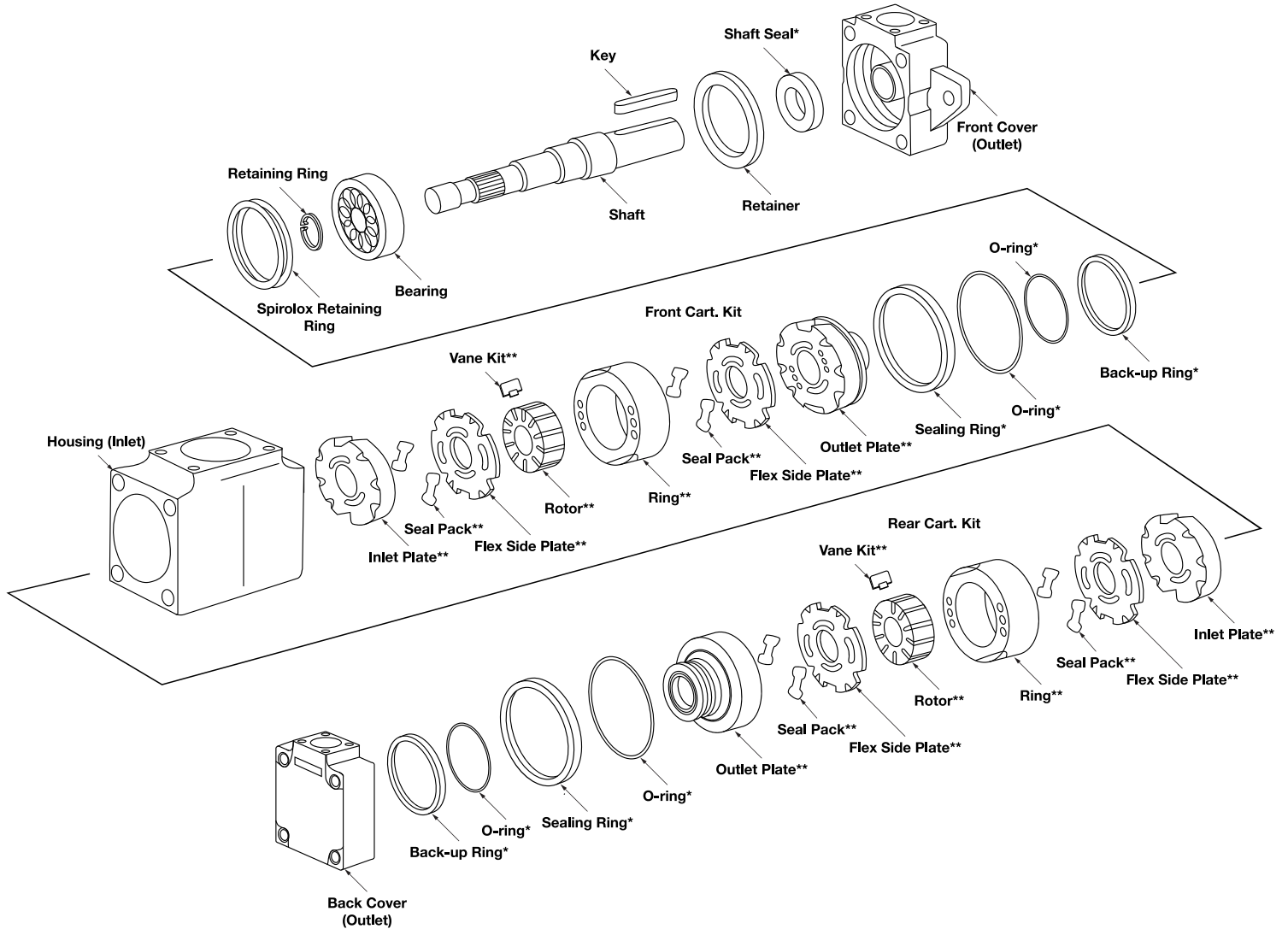

4535VQ

\* Included in Seal Kit  
 \*\* Included in Cartridge Kit

# VQ Series - Mobile Double Pump

## Parts Breakdown Listing

PUMP	FRONT CART. KIT	ROTOR	VANE KIT	RING	FLEX PLT.	REAR CART. KIT	ROTOR	VANE KIT	RING	FLEX PLT.	SHAFTS		
2520VQ	12 416439			326984		2 417052			388693				
	14 416440	270597	922710	326985	923956	5 417053	402690	922741	333624				
	17 416441			326986				8 417054			333625	923955	1 254964
	21 416442			326988				11 416427			333626		11 254848
							12 416428	403539	922743	353901		25 293360	
						14 416429			353902				
3520VQ	21 413420			394961		2 417052			388693				
	25 413421			319396		5 417053	402690	922741	333624		1 258249		
	30 413422	262154	922700	319397	923953	8 417054			333625	923955	11 254848		
	35 413418			319398		11 416427			333626		86 394517		
	38 413419			319399		12 416428	403539	922743	353901		113 413022		
						14 416429			353902		114 413434		
3525VQ	21 413420			394961		12 421244			326984				
	25 413421			319396		14 421235	270597	922710	326985	923956	1 243448		
	30 413422	262154	922700	319397	923953	17 421236			326986		11 243449		
	35 413418			319398							19 247019		
	38 413419			319399							111 413023		
4520VQ	42 416435			297510		2 417052			388693				
	50 416436	283871	922701	297502	923954	5 417053	402690	922741	333624		1 255533		
	60 416437			297503		8 417054			333625	923955	11 255536		
						11 416427			333626		86 361761		
						12 416428	403539	922743	353901		114 413436		
						14 416429			353902				
4525VQ	42 416435			297510		12 421244			326984				
	50 416436	283871	922701	297502	923954	14 421235	270597	922710	326985	923956	1 233524		
	60 416437			297503		17 421236			326986		11 233527		
					21 421238	326988			86 361762				
											114 413024		
4535VQ	42 416435			297510		25 421239			319396		1 289083		
	50 416436	283871	922701	297502	923954	30 421240	262154	922700	319397	923953	11 289084		
	60 416437			297503		35 421242			319398		86 361763		
					38 421243	319399			114 413027				

PUMP	BUNA SEAL KIT	VITON SEAL KIT	BUNA SHAFT SEAL	VITON SHAFT SEAL	SECONDARY SHAFT SEAL	BEARING	FRONT COVER	MIDDLE COVER	BACK COVER
2520VQ	920040	920042	394976	429286	429283	001705	942353	251263	250824
3520VQ	920048	920050	394973	429284	429281	038441	942355	250818	250824
3525VQ	920056	920058	394973	429284	429281	038441	942355	230189	231532
4520VQ	920060	920062	394974	429285	429282	131812	942356	252283	250824
4525VQ	920068	920070	394974	429285	429282	131812	942356	370071	231532
4535VQ	920072	920074	394974	429285	429282	131812	942356	270640	270679

# VQ Series - Mobile Double Pump

## Bolt Torques

PUMP	FRONT HOUSING - FT. LB.	REAR COVER - FT. LB.	FRONT CART. KIT - IN LB.	REAR CART. KIT - IN. LB.
2520VQ	75 (101.7 Nm)	50 (67.8 Nm)	45 (5.1 Nm)	30 (3.4 Nm)
3520VQ	150 (203.4 Nm)	50 (67.8 Nm)	100 (11.3 Nm)	30 (3.4 Nm)
3525VQ	150 (203.4 Nm)	75 (101.7 Nm)	100 (11.3 Nm)	45 (5.1 Nm)
4520VQ	275 (372.8 Nm)	50 (67.8 Nm)	105 (11.8 Nm)	30 (3.4 Nm)
4525VQ	275 (372.8 Nm)	75 (101.7 Nm)	105 (11.8 Nm)	45 (5.1 Nm)
4535VQ	275 (372.8 Nm)	na	105 (11.8 Nm)	100 (11.3 Nm)

## Changing Cartridge Rotation

To change Cartridge Kit rotation, reverse the location of the inlet and the outlet support plates. Hand tighten the cartridge screws and use pump cover to align all the parts. Remove the cover and tighten the cartridge screws to the designated value. Sharp edge of vanes must lead in direction of rotation.

## Filtration

For satisfactory service life, use full flow filtration to provide fluid which meets ISO cleanliness code 19/17 or better.



# V/VQ Series - Double Pump

## Dimensions

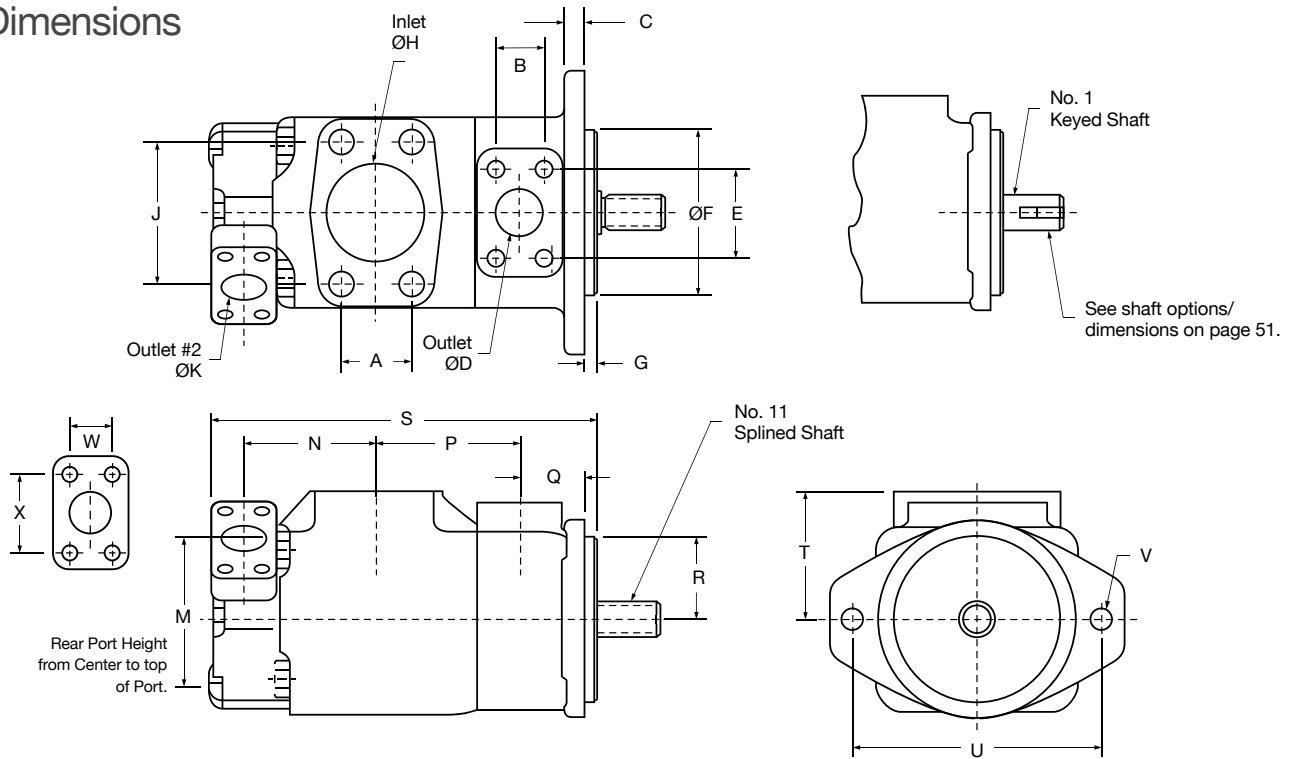

**2520V/2520VQ, 3520V/3520VQ, 3525V/3525VQ  
4520V/4520VQ, 4525V/4525VQ**

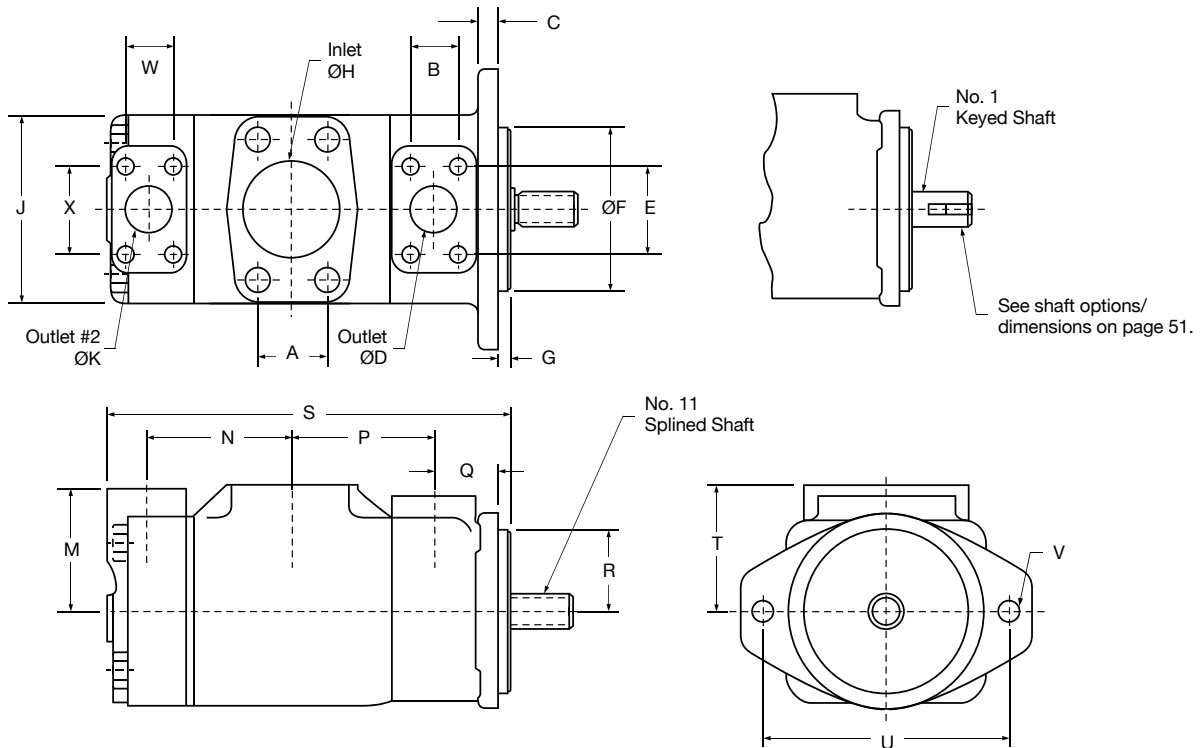

**4535V/4535VQ**

# V/VQ Series - Double Pump

## Dimensions Chart

	2520	3520	3525	4520	4525	4535
<b>A</b>	2.00 (50.8)	2.44 (62.0)	2.44 (62.0)	2.75 (69.9)	2.75 (69.9)	3.06 (77.7)
<b>B</b>	1.03 (26.2)	1.19 (30.2)	1.19 (30.2)	1.41 (35.8)	1.41 (35.8)	1.41 (35.8)
<b>C</b>	0.50 (12.7)	0.62 (15.7)	0.62 (15.7)	0.62 (15.7)	0.62 (15.7)	0.62 (15.7)
<b>D</b>	1.00 (25.4)	1.25 (31.8)	1.25 (31.8)	1.50 (38.1)	1.50 (38.1)	1.50 (38.1)
<b>E</b>	2.06 (52.3)	2.31 (58.7)	2.31 (58.7)	2.75 (69.9)	2.75 (69.9)	2.75 (69.9)
<b>F</b>	4.0-3.9 (101.6-99.1)	5.0-4.9 (127-124.5)	5.0-4.9 (127-124.5)	5.0-4.9 (127-124.5)	5.0-4.9 (127-124.5)	5.0-4.9 (127-124.5)
<b>G</b>	0.38 (9.65)	0.38 (9.65)	0.38 (9.65)	0.50 (12.7)	0.50 (12.7)	0.50 (12.7)
<b>H</b>	2.50 (63.5)	3.00 (76.2)	3.00 (76.2)	3.50 (88.9)	3.50 (88.9)	4.00 (101.6)
<b>J</b>	3.50 (88.9)	4.19 (106.4)	4.19 (106.4)	4.75 (120.7)	4.75 (120.7)	5.13 (130.3)
<b>K</b>	0.75 (19.1)	0.75 (19.1)	1.00 (25.4)	0.75 (19.1)	1.00 (25.4)	1.25 (31.8)
<b>M</b>	3.00 (76.2)	3.00 (76.2)	2.94 (74.7)	3.00 (76.2)	2.94 (74.7)	4.00 (101.6)
<b>N</b>	3.47 (88.1)	3.92 (99.6)	4.31 (109.5)	4.72 (119.9)	5.35 (135.9)	5.84 (148.3)
<b>P</b>	4.00 (101.6)	4.50 (114.3)	4.50 (114.3)	4.70 (119.4)	4.70 (119.4)	5.25 (133.4)
<b>Q</b>	1.50 (38.1)	1.50 (38.1)	1.50 (38.1)	1.69 (43.0)	1.69 (43.0)	1.69 (43.0)
<b>R</b>	3.00 (76.2)	3.25 (82.6)	3.25 (82.6)	3.69 (93.7)	3.69 (93.7)	3.69 (93.7)
<b>S</b>	9.81 (249.2)	10.8 (274.3)	9.81 (249.2)	11.95 (303.5)	12.8 (325.1)	13.9 (353.1)
<b>T</b>	3.38 (85.9)	3.50 (88.9)	3.50 (88.9)	4.03 (102.4)	4.03 (102.4)	4.03 (102.4)
<b>U</b>	5.75 (146.1)	7.13 (181.1)	7.13 (181.1)	7.13 (181.1)	7.13 (181.1)	7.13 (181.1)
<b>V</b>	0.56 (14.2)	0.69 (17.5)	0.69 (17.5)	0.69 (17.5)	0.69 (17.5)	0.69 (17.5)
<b>W</b>	0.88 (22.4)	0.88 (22.4)	1.03 (26.2)	0.88 (22.4)	1.03 (26.2)	1.19 (30.2)
<b>X</b>	1.88 (47.8)	1.88 (47.8)	2.06 (52.3)	1.88 (47.8)	2.06 (52.3)	2.31 (58.7)

Dimensions are in inches (millimeters).

# V/VQ Series - Double Pump

## Straight Key Shaft Dimensions Chart

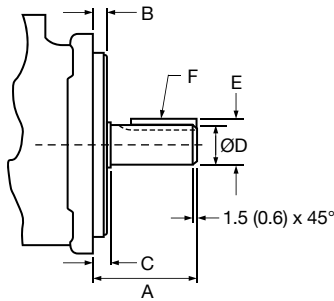

PUMP	SHAFT CODE	A	B	C	ØD	E	F (KEY WIDTH X LENGTH)
25V 2520V/VQ	1	2.32 (59)	.375 (9.53)	.435 (11.1)	.875 (22.23)	.966 (24.5)	.817 (4.75) x
					.874 (22.20)	.961 (24.4)	1.25 (32)
25V 252*V/VQ	86	3.06 (78)	.375 (9.53)	.435 (11.1)	.999 (25.37)	1.11 (28.3)	.250 (6.36) x
					.998 (25.35)	1.10 (28.1)	2.00 (50.8)
35V 352*V/VQ	1	2.88 (73.2)	.375 (9.53)	.435 (11.1)	1.25 (31.75)	1.39 (35.36)	.313 (7.94) x
					1.24 (31.70)	1.38 (34.10)	1.50 (38.1)
35V 352*V/VQ	86	3.88 (86)	.375 (9.53)	.435 (11.1)	1.374 (34.90)	1.52 (38.6)	.312 (7.92) x
					1.373 (34.87)	1.51 (38.3)	2.13 (54)
45V 45**V/VQ	1	2.44 (62)	.500 (12.7)	.560 (14.22)	1.25 (31.75)	1.39 (35.36)	.312 (7.92) x
					1.24 (31.70)	1.38 (34.10)	1.12 (28.5)
45V 45**V/VQ	86	3.44 (87.4)	.500 (12.7)	.560 (14.22)	1.499 (38.07)	1.67 (42.4)	.375 (9.53) x
					1.498 (38.05)	1.66 (42.1)	2.00 (50.8)

Dimensions are in inches (millimeters).

## Splined Shaft Dimensions Chart

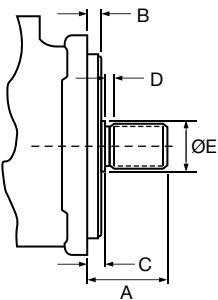

PUMP	SHAFT CODE	A	B	C	D	ØE	# OF TEETH	PITCH	MAJOR DIAM.	MINOR DIAM.
25V 2520V/VQ	11	1.75	.375	.437	.156	1.09	13	16/32	.873 (22.17)	.734 (18.63)
		(44.5)	(9.53)	(11.1)	(3.9)	(27.8)			.872 (22.15)	.723 (18.35)
35V 352*V/VQ	11	2.31	.375	.437	.25	1.38	14	12/24	1.25 (31.7)	1.06 (26.99)
		(58.7)	(9.53)	(11.1)	(6.35)	(35.1)			1.247 (31.67)	1.05 (26.64)
45V 45**V/VQ	11	2.44	.500	.565	.38	1.56	14	12/24	1.25 (31.7)	1.06 (26.99)
		(61.9)	(12.7)	(14.3)	(9.7)	(39.6)			1.247 (31.67)	1.05 (26.64)

Dimensions are in inches (millimeters).

# V/VQ Series - Thru-drive Single Pump

## Features

Intravane design pumps provide longer life and increased productivity. Not to mention, they provide application versatility. These units are also known for extremely low sound levels, making them perfect for mobile applications. Compact size and ease of service allow maximum equipment design flexibility. Pumps are available in single, double and thru-drive configurations.

- High Volumetric Efficiency
- Maximum 3000 psi (207 bar) Operating Pressure
- High Operating Speeds
- Versatile and Compact



## Specifications

PUMP	FLOW IN GPM @ 1200 RPM & 100 PSI (LPM)	DISPL. IN <sup>3</sup> /R (CM <sup>3</sup> /R)	MAX. SPEED (RPM)	MAX. PRESSURE PSI (BAR)	TYP. DELIVERY GPM @ MAX. SPEED & PRESSURE (LPM)	TYPICAL INPUT POWER (HP) @ MAX. SPEED & PRESSURE (KW)	WEIGHT LBS (KGS)
<b>25VT*</b> <b>25VQT*</b>	12 (45.4)	2.45 (40.1)	2700	3000 (207)	23.0 (87.1)	55.0 (41.0)	43 (19.5)
	14 (53.0)	2.77 (45.4)	2700	3000 (207)	27.0 (102.2)	62.5 (46.6)	
	17 (64.4)	3.39 (55.6)	2500	3000 (207)	31.0 (117.3)	69.5 (51.8)	
	19 (71.9)	3.72 (61.0)	2500	3000 (207)	35.0 (132.5)	76.0 (56.7)	
	21 (79.5)	4.12 (67.5)	2500	3000 (207)	38.0 (143.8)	83.0 (61.9)	
<b>35VT*</b> <b>35VQT*</b>	21 (79.5)	4.12 (67.5)	2500	3000 (207)	38.0 (143.8)	83.0 (61.9)	63 (28.6)
	25 (94.6)	4.98 (81.6)	2500	3000 (207)	45.0 (170.3)	101.0 (75.3)	
	30 (113.6)	5.96 (97.7)	2500	3000 (207)	55.0 (208.2)	117.5 (87.6)	
	35 (132.5)	6.88 (112.7)	2400	3000 (207)	60.0 (227.1)	132.0 (98.4)	
<b>45VT*</b> <b>45VQT*</b>	38 (143.8)	7.42 (121.6)	2400	3000 (207)	65.0 (246.1)	140.0 (104.4)	84 (38.1)
	42 (159.0)	8.46 (138.6)	2200	2500 (172)	66.5 (251.7)	122.5 (91.3)	
	45 (170.3)	8.95 (146.7)	2200	2500 (172)	71.0 (268.8)	131.0 (97.7)	
	50 (189.3)	9.90 (162.2)	2200	2500 (172)	79.0 (299.0)	141.0 (105.1)	
	60 (227.1)	11.80 (193.4)	2200	2500 (172)	96.0 (363.4)	170.0 (126.8)	

Values based on using anti-wear type petroleum oil 150 SUS at 100° F (ISO rating of 32 cSt at 38° C) and 0 psi inlet pressure.

# V/VQ Series - Thru-drive Single Pump

## Model Code Breakdown

**35 - VT - A - S - 38 - A - (S) - 2 - 203 - C - A - 20 - R**

**Model**  
25  
35  
45

**Series**  
VT = Industrial Series Thru-drive  
VQT = Mobile Series Thru-drive

**Thru-drive Connections**  
(Mounting Adapter 2-Bolt)  
SAE Designation J744C  
A = A  
B = B  
BP = Special mounting w/spacer for Vickers PVE12/19/21  
C = C (Not available on 25VQT)

**Front Mounting Flange**  
SAE Designation J744C

**Ring Capacity in U.S. gpm**  
Rated capacity at 1200 rpm & 100 psi

Frame Size	Code (US gpm)	cm <sup>3</sup> /r	in <sup>3</sup> /r
25V/VQ	12	40	2.45
	14	45	2.77
	17	55	3.39
	19	61	3.72
	21	67	4.12
35V/VQ	25	81	4.98
	30	97	5.96
	35	112	6.88
45V/VQ	38	121	7.42
	42	138	8.46
	45	147	8.95
	50	162	9.90
	60	193	11.80

**Shaft Rotation**  
(Viewed from shaft end of pump)  
R = Right-hand (Clockwise) Rotation  
L = Left-hand (Counter-Clockwise) Rotation

**Design**

**Adapter Mounting Orientation**  
(Viewed from cover end of pump)  
A = Rotated 45° CW with respect to pump mtg. flg.  
B = Rotated 45° CCW with respect to pump mtg. flg.

**Outlet Position**  
(Viewed from cover end of pump)  
A = Outlet opposite of inlet  
B = Outlet 90° CCW from inlet  
C = Outlet inline with inlet  
D = Outlet 90° CW from inlet

**Shaft**  
203 = Heavy duty straight key  
297 = Splined

**Coupling for Tandem Pump**  
2 = SAE splined coupling included with pump

**Double Shaft Seal**  
S = Double shaft seal  
Omit for single shaft seal

**Port Connections**  
A = SAE 4-Bolt Flange

# V/VQ Series - Thru-drive Single Pump

## Dimensions

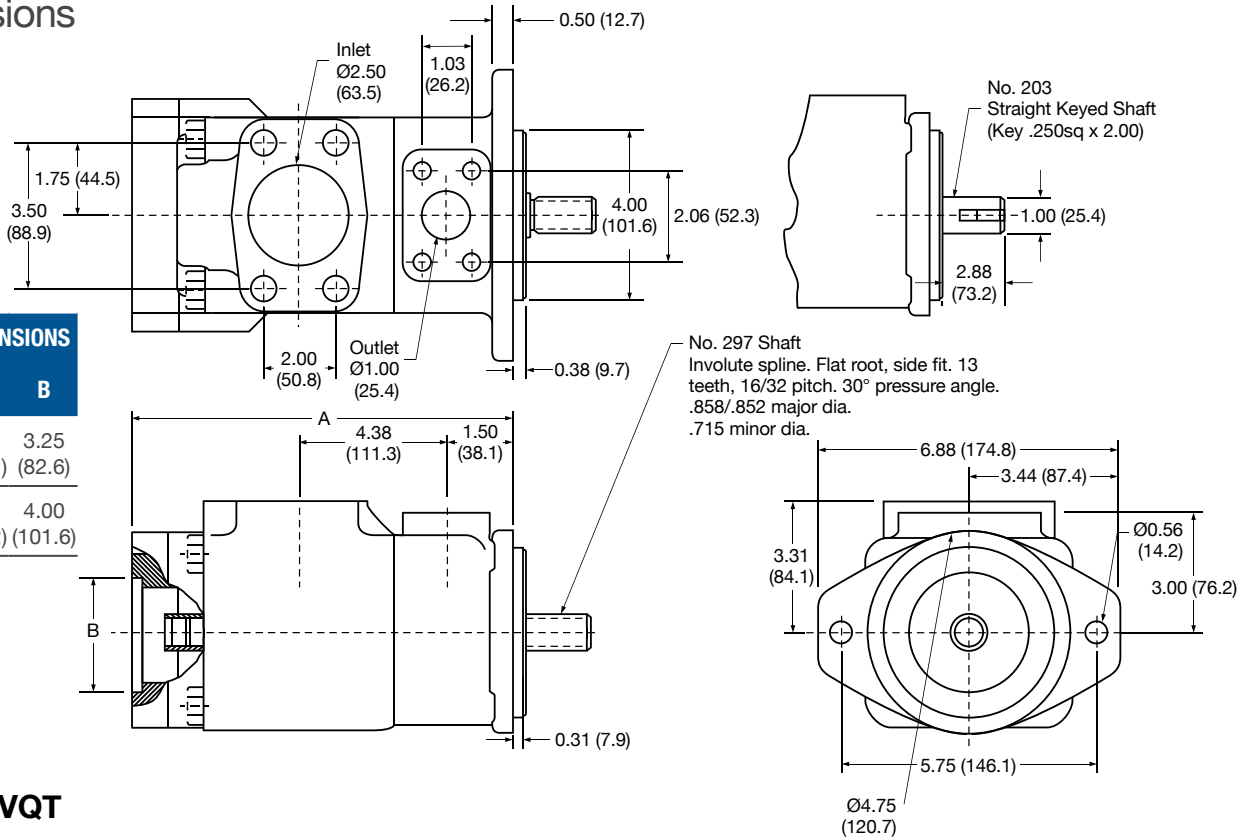

SERIES	DIMENSIONS	
	A	B
25VTA	8.94 (227.1)	3.25 (82.6)
25VTB	9.30 (236.2)	4.00 (101.6)

### 25VT/25VQT

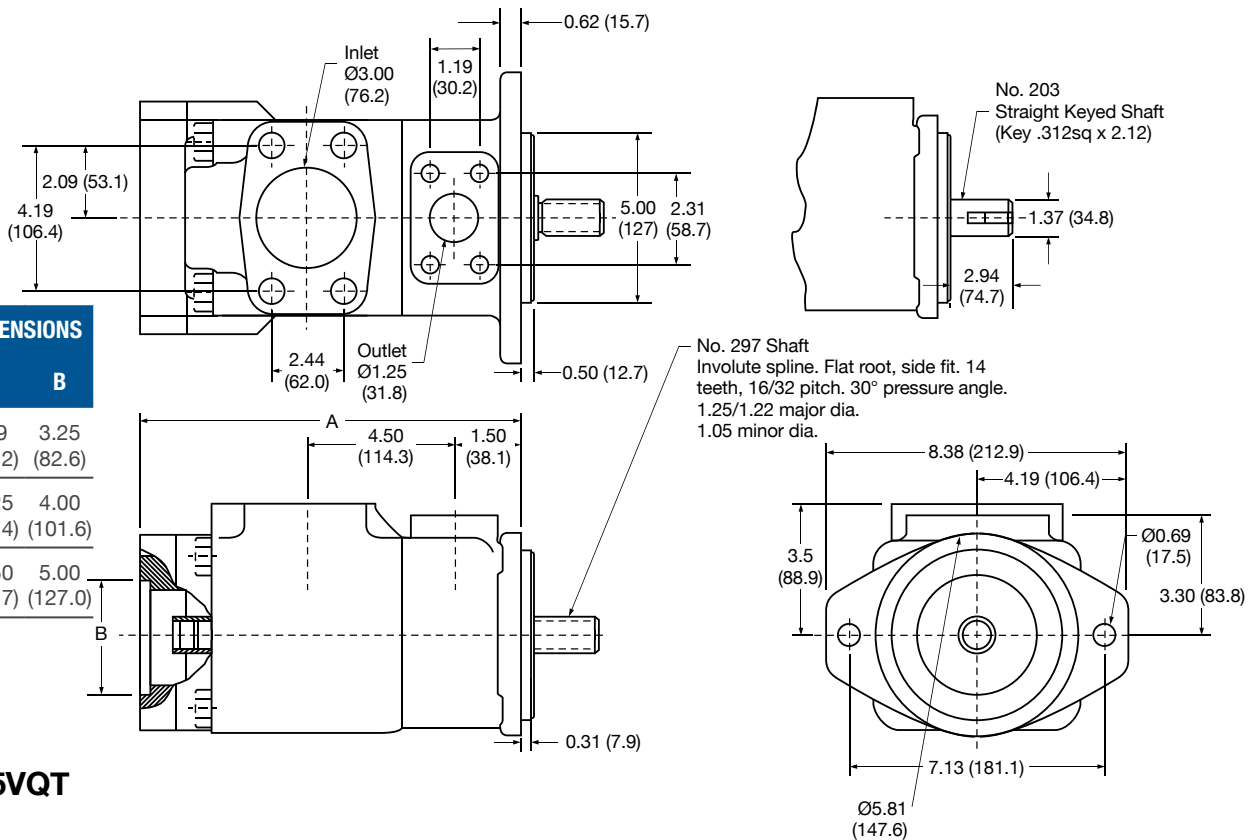

SERIES	DIMENSIONS	
	A	B
35VTA	9.89 (251.2)	3.25 (82.6)
35VTB	10.25 (260.4)	4.00 (101.6)
35VTC	10.50 (266.7)	5.00 (127.0)

### 35VT/35VQT

# V/VQ Series - Thru-drive Single Pump

## Dimensions

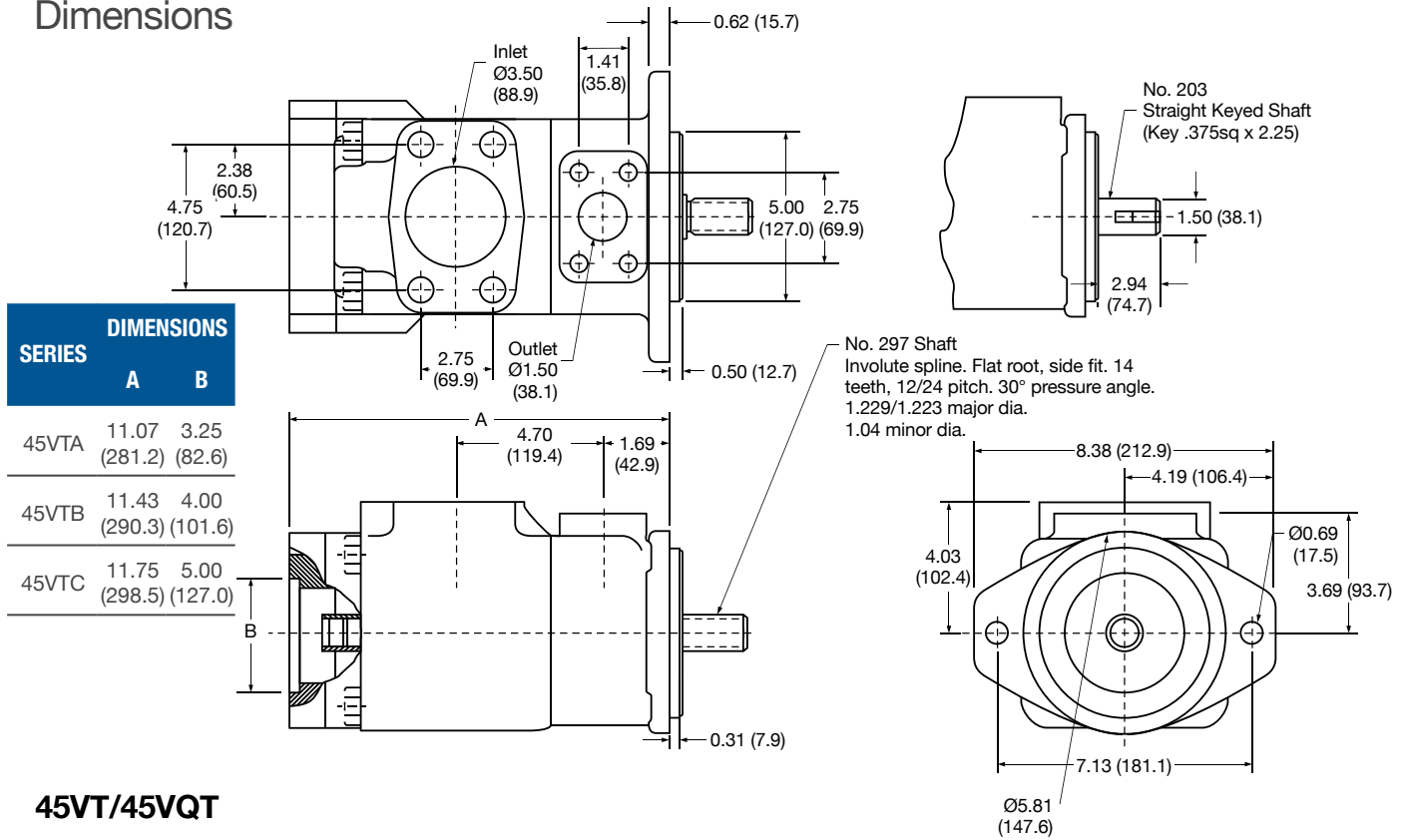

### 45VT/45VQT

# V/VQ Series - Thru-drive Single Pump Rear Mountings

## Dimensions

### 'A' Rear Mount

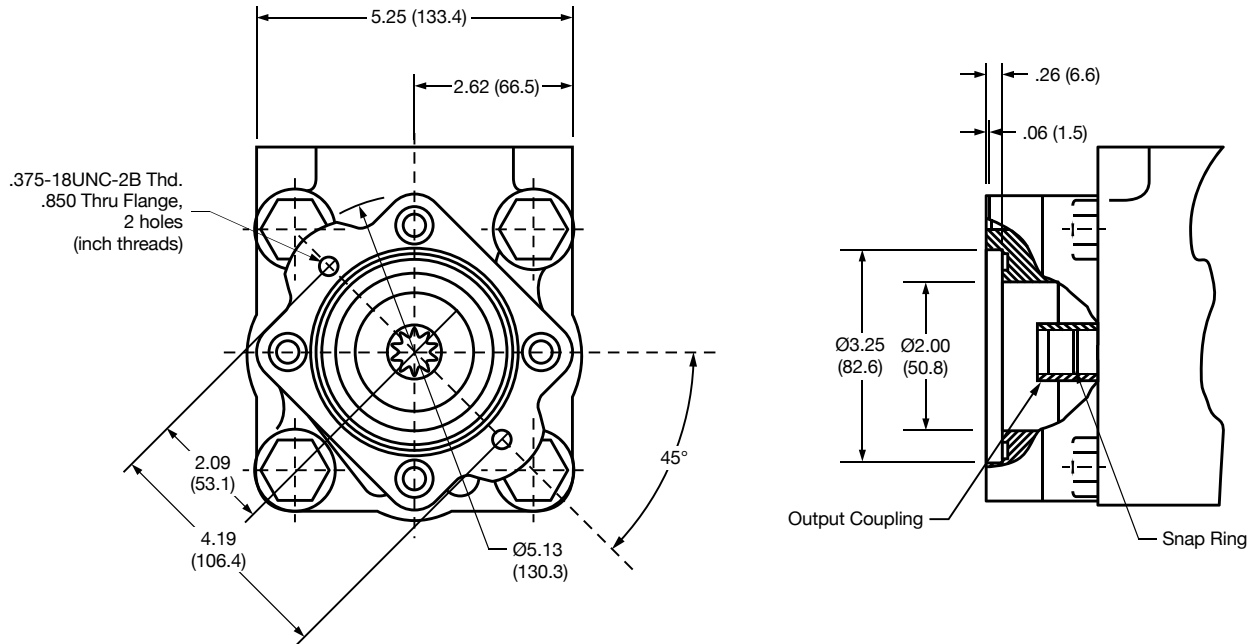

### 'B' Rear Mount

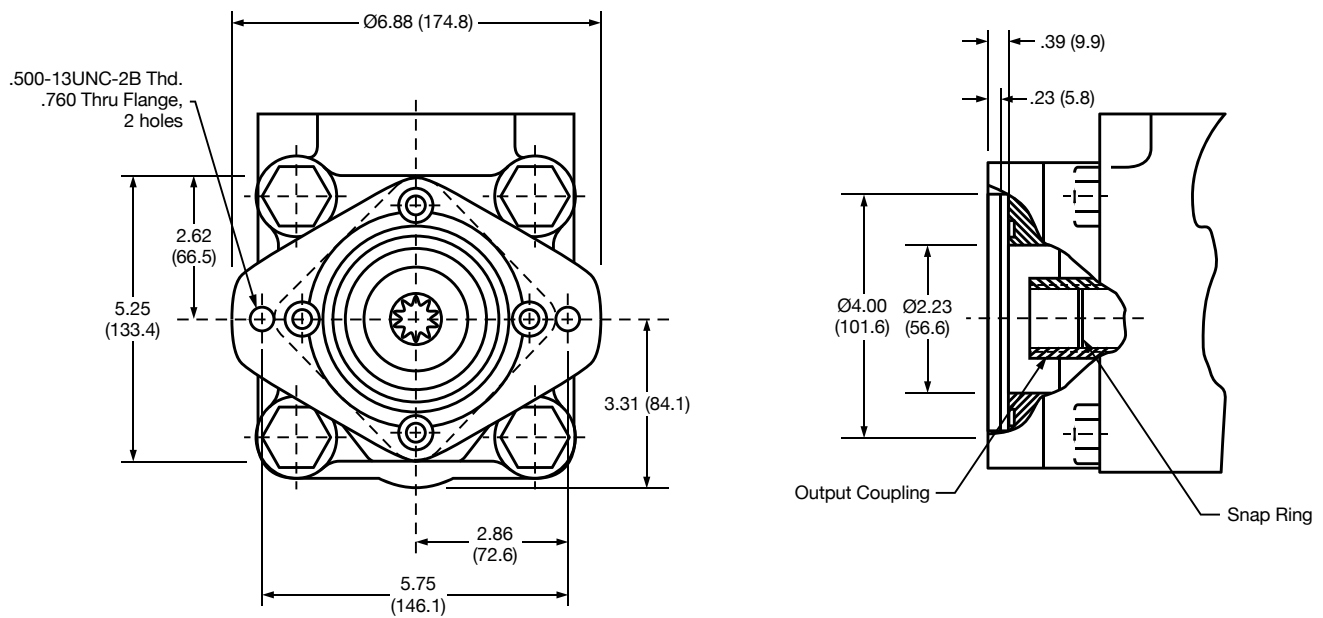



# V/VQ Series - Thru-drive Single Pump Rear Mountings

## Dimensions

### 'BP' Rear Mount

This SAE "B" size unit with spacer accepts a Vickers PVE12/19/21 pump.  
The output coupling is for a pump shaft of SAE "B" size.

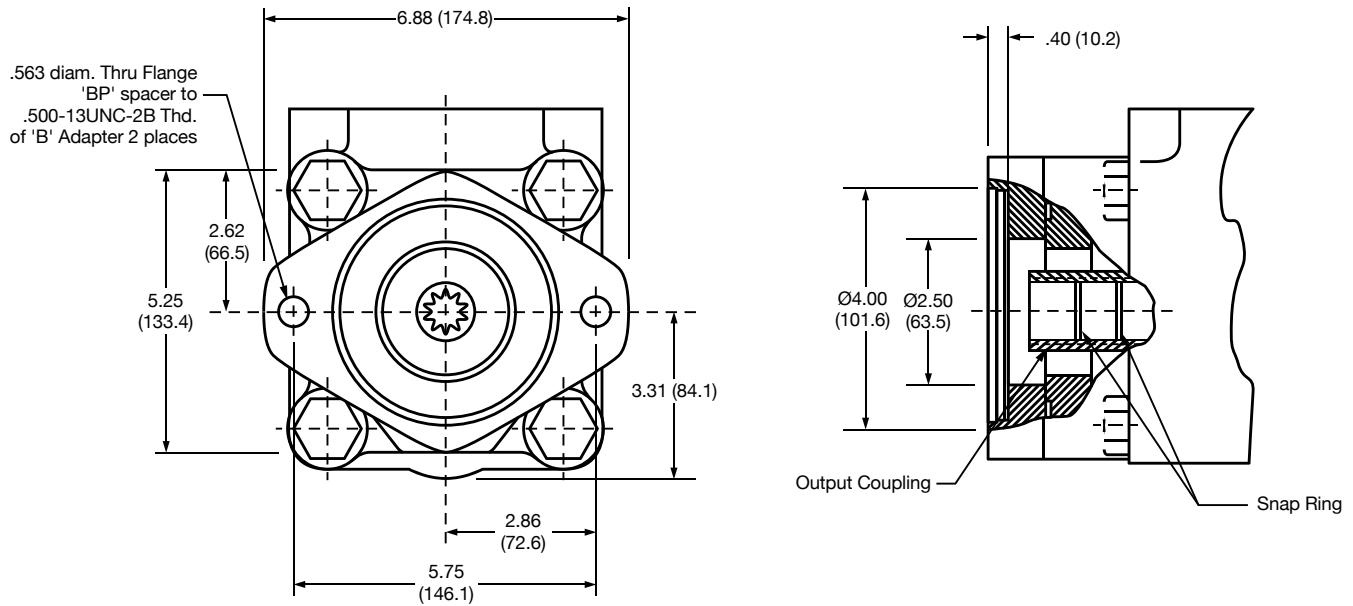

### 'C' Rear Mount

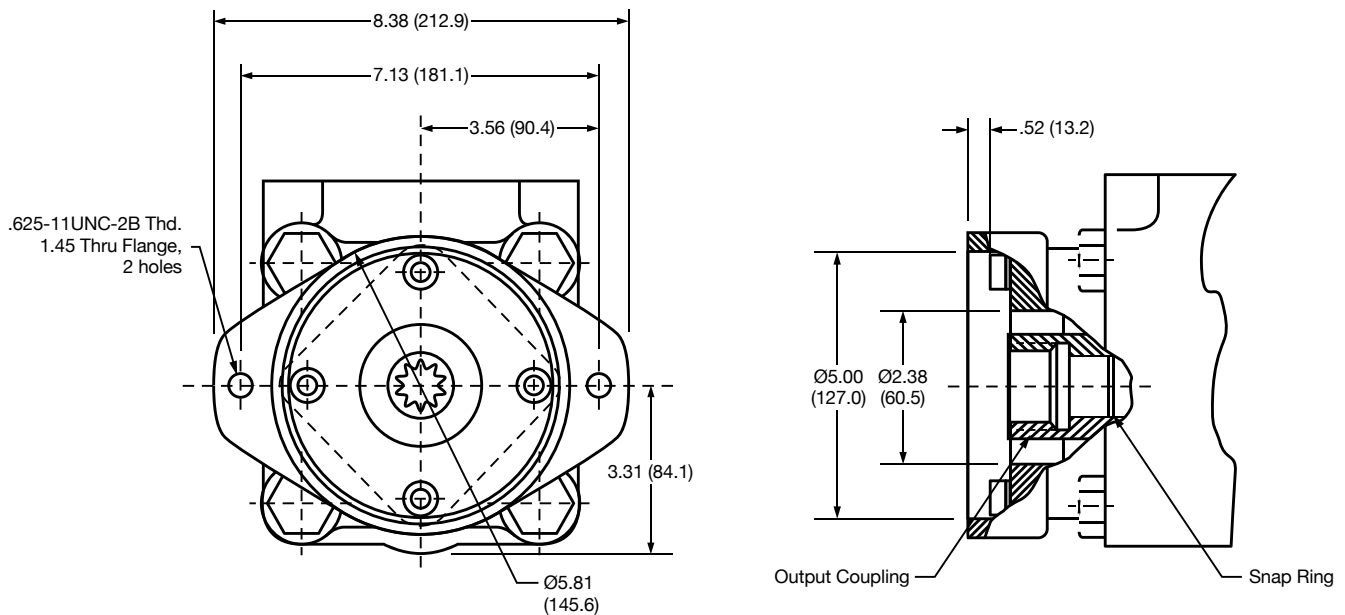

# V/VQ Series

## Maximum Torque Loading

### Single Pumps

All listed shafts are satisfactory up to maximum pressures in listed in the corresponding pump/series' operating data.

### Double Pumps

Where both cartridges are to be on-load together, check that the sum of their separate torques do not exceed the torque limit of the desired shaft.

### Single Thru-drive Pumps

Where both the thru-drive pump and its rear-mounted pump are to be on-load together, check that the sum of the torques generated will never exceed the torque limit in shaft torque tables below. Also check that the torque required on the rear-mounted pump never exceeds the thru-drive torque limit in tables below.

## Shaft Torque Ratings

PUMP	SHAFT NUMBER	MAXIMUM INPUT TORQUE NM (LB. IN.)
25VQ or 25**VQ	1	316 (2800)
	86	402 (3560)
	11	316 (2800)
	123	316 (2800)
	203	402 (3560)
	297	344 (3040)
35VQ or 35**VQ	1	402 (3560)
	11	791 (7000)
	86	659 (5830)
	123	791 (7000)
	203	659 (5830)
	297	791 (7000)
45VQ or 45**VQ	1	402 (3560)
	11	1017 (9000)
	86	982 (8690)
	130	1017 (9000)
	203	982 (8690)
	297	1017 (9000)

PUMP	SHAFT NUMBER	MAXIMUM INPUT TORQUE NM (LB. IN.)	THRU-DRIVE CONNECTION	MAX. THRU-DRIVE TORQUE NM (LB. IN.)
25VQT	203	402 (3560)	A	131 (1160)
			B	316 (2800)
25VQT	297	344 (3040)	A	131 (1160)
			B	316 (2800)
35VQT	203	6589 (5830)	A	131 (1160)
			B	348 (3080)
			C	437 (3870)
35VQT	297	791 (7000)	A	131 (1160)
			B	348 (3080)
			C	437 (3870)
45VQT	203	982 (8690)	A	131 (1160)
			B	384 (3400)
			C	702 (6210)
45VQT	297	1017 (9000)	A	131 (1160)
			B	384 (3400)
			C	702 (6210)

Example: A 3525VQ38A17 pump operating at 175 bar (2500 psi) front section and 140 bar (2000 psi) rear section will require over 452 Nm (4000 lb. in.) input torque. Therefore, all listed shafts are acceptable except No. 1.

# VQH 32 Series

## High Pressure Pumps & Cartridge Kits

PUMP	GPM @ 1200 RPM & 100 PSI (LPM)	DISPLACEMENT CM <sup>3</sup> /R (IN <sup>3</sup> /R)	MAX RPM	MAX CONTINUOUS BAR (PSI)	MAX PEAK BAR (PSI)
35VQH	30 (113.6)	97.7 (5.96)	2500	228 (3300)	248 (3600)
	35 (132.5)	112.8 (6.88)	2400	228 (3300)	248 (3600)
	38 (143.8)	121.6 (7.42)	2400	228 (3300)	248 (3600)
45VQH	50 (189.3)	162.3 (9.90)	2200	228 (3300)	248 (3600)
	57 (215.8)	190.2 (11.61)	2200	228 (3300)	248 (3600)
	60 (227.1)	193.4 (11.80)	2200	207 (3000)	248 (3600)

### Pump Models

- 35VQH
- 3520VQH
- 45VQH
- 3525VQHVQH10/V20
- 3520VQH
- 4520VQHVQH10/V20
- 3525VQH
- 4525VQHVQH10/V20
- 4520VQH
- 4535VQHVQH10/V20
- 4525VQH
- 4535VQH

### Cartridge Kits

Metaris VQH cartridge kits employ a new 2-piece rotor design as well as hardened Cam Ring and Vanes that improve efficiency and pressure capability.

- 35VQH - 30, 35, 38 gpm (113.6, 132.5, 143.8 lpm)
- 45VQH - 50, 57, 60 gpm (189.3, 215.8, 227.1 lpm)

# Pump & Cartridge Identification

## Cartridge Kit Dimensions and Flow

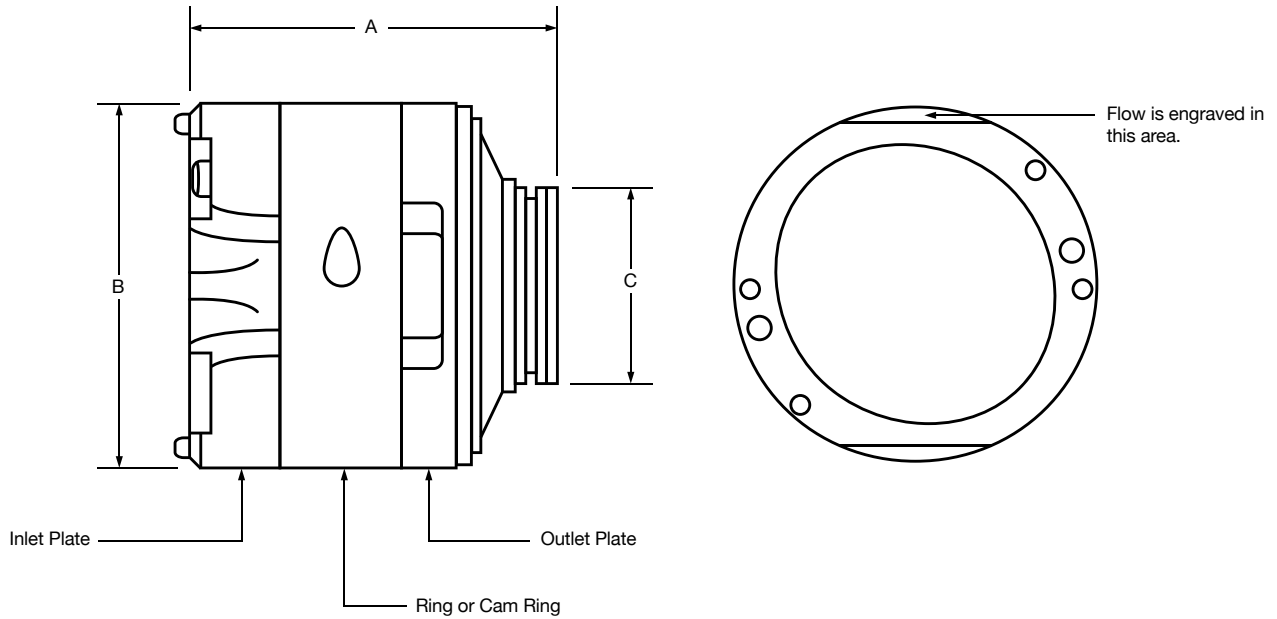

DIMS.	20V SERIES	25V SERIES	30V SERIES	35V SERIES	45V SERIES
<b>A</b>	3.22 (81.8)	3.92 (99.6)	4.35 (110.5)	4.66 (118.4)	5.53 (140.5)
<b>B</b>	3.25 (82.6)	3.81 (96.8)	3.81 (96.8)	4.50 (114.3)	5.25 (133.4)
<b>C</b>	1.86 (47.2)	2.05 (52.1)	2.05 (52.1)	2.84 (72.1)	3.16 (80.3)
<b>Weight</b>	5.07 lbs (2.3 kgs)	8.34 lbs (3.8 kgs)	9.04 lbs (4.1 kgs)	14.11 lbs (6.4 kgs)	22.49 lbs (10.2 kgs)
	2 (7.6)	8 (30.3)	24 (90.8)	21 (79.5)	42 (159.0)
	5 (18.9)	12 (45.4)	28 (106.0)	25 (94.6)	47 (177.9)
<b>Flow (in gal. at 1200 rpm) (lpm)</b>	8 (30.3)	14 (53.0)		30 (113.6)	50 (189.2)
	9 (34.1)	17 (64.4)		35 (132.4)	57 (215.8)
	11 (41.6)	19 (72.0)		38 (143.8)	60 (227.1)
	12 (45.4)	21 (79.5)			
	14 (53.0)				

# Pump & Cartridge Identification

## Pump Rotation

To determine pump rotation look at it from the shaft end side. So, if clockwise, it is right hand rotation, if counter-clockwise, it is left hand rotation.

When taking out the cartridge and putting it on to the outlet plate, take into account that rotation is seen the other way round; an arrow engraved in the ring or cam ring shows the real turning sense/direction.

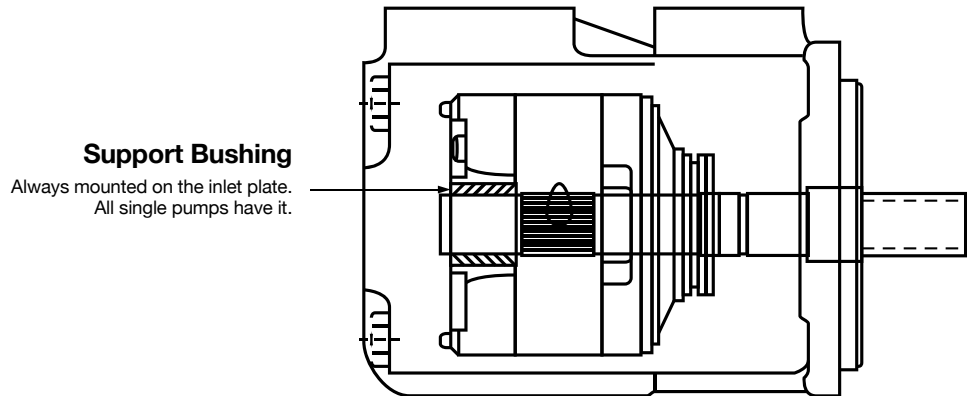

**Pump Rotation**  
Always viewed from the  
shaft end side.

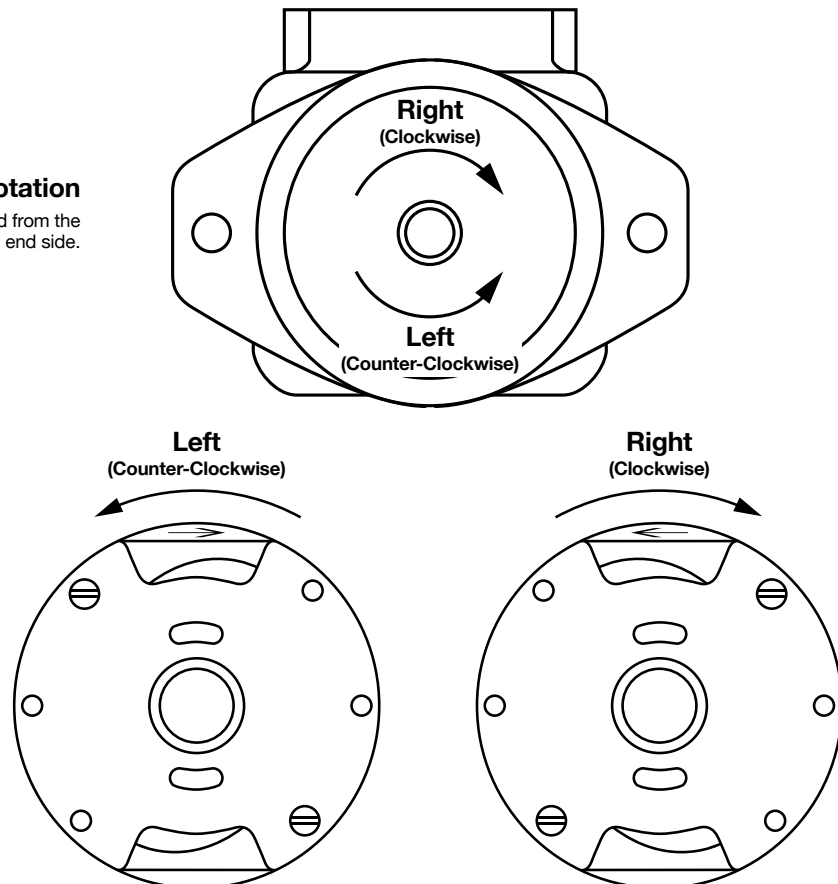

# Pump & Cartridge Identification

## Pump Rotation

A double pump is setup so that the 2 cartridges are opposite to each other, therefore when putting them on the outlet plate, they will apparently have opposite turning sense. The arrow in the ring shows the correct rotation. (Pump and cover end cartridge rotation always coincide.) See diagrams below.

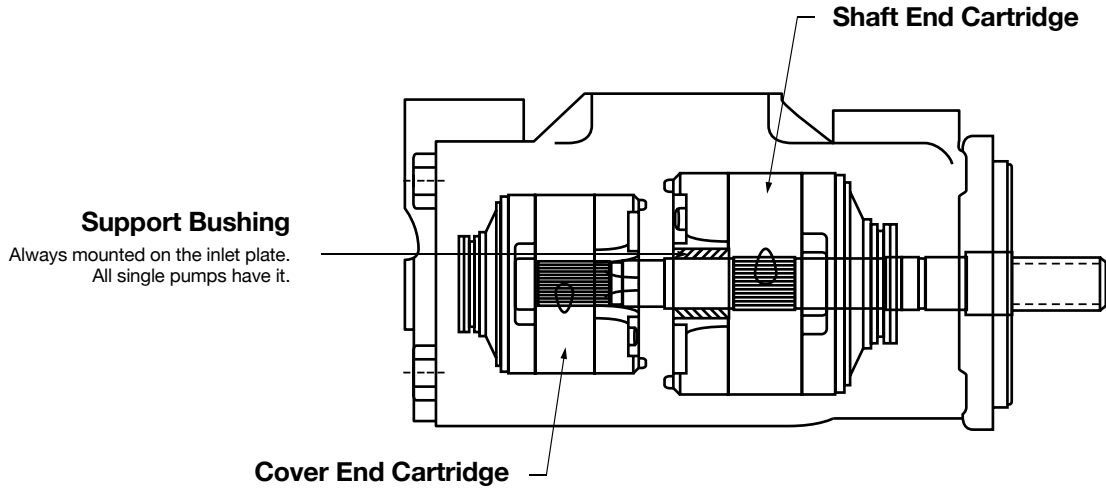

### Pump Rotation

Always viewed from the shaft end side.

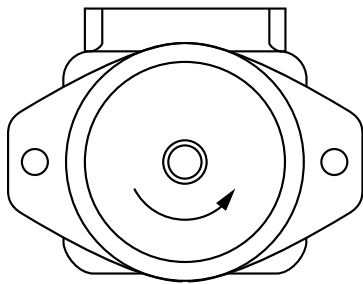

**Left**  
(Counter-Clockwise)

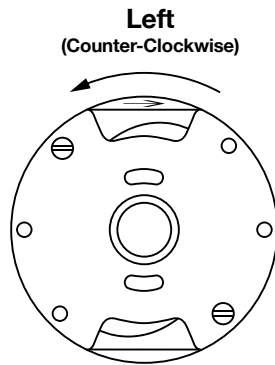

**Left**  
(Counter-Clockwise)

**Shaft End Cartridge**

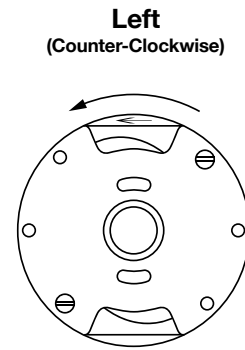

**Left**  
(Counter-Clockwise)

**Cover End Cartridge**

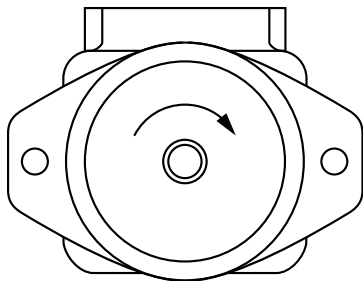

**Right**  
(Clockwise)

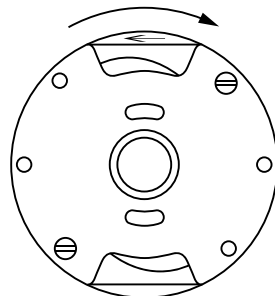

**Right**  
(Clockwise)

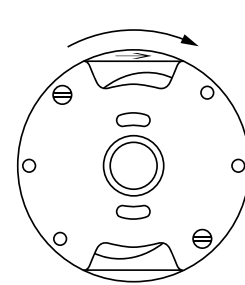

**Right**  
(Clockwise)

# Hydralex - A Recognized Global Leading Provider of High Quality Hydraulic Components

## Products We Offer

- Inline Piston Pumps
- Radial Piston Pumps & Motors
- Bent Axis Piston Pumps & Motors
- Fixed Volume Vane Pumps
- Variable Volume Vane Pumps
- Gear Pumps
- Vane Motors
- Axial Piston Motors
- High Speed Motors
- Servo Motors
- Orbital Motors
- Directional Valves
- Flow Control Valves
- Pressure Control Valves
- Relief Valves
- Check Valves
- Stack Valves
- Servo Valves
- Proportional Valves
- PTOs (Power Take-offs)
- Cylinders



Hydralex Corporate  
48175 Gratiot Ave  
Chesterfield, MI 48051  
Toll Free: 800.422.4279  
Tel: 586.949.4240

[www.hydralex.com](http://www.hydralex.com)

Hydralex Detroit  
Hydralex Jackson  
Hydralex Seattle  
Hydralex Memphis

Tel: 586.949.4240  
Tel: 601.469.1987  
Tel: 253.604.0400  
Tel: 901.794.2462

[sales@hydralex.com](mailto:sales@hydralex.com)  
[sales@metarisusa.com](mailto:sales@metarisusa.com)  
[hrdsales@hydralex.com](mailto:hrdsales@hydralex.com)  
[fhisales@hydralex.com](mailto:fhisales@hydralex.com)



Connect with us:



All manufacturers names, symbols and descriptions in this document are used for reference purposes only, and it is not implied that any parts listed is the product of these manufacturers.